

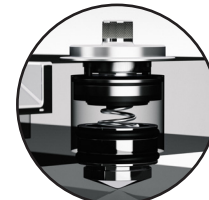

3-point pivot tonearm with improved counterweight system



High end spring loaded, adjustable feet



Elegant and luxurious motor control panel

\*Pictured with separately available Pick it MC9

# Signature 12.2

## Pro-Ject's high-end flagship turntable

colour options: ●

MSRP without cartridge 12.000 € (incl. VAT)

- **NEW** 3-point pivot tonearm bearing construction
- **NEW** modified counterweight system
- **NEW** motors mounted in full aluminium motor block for even more effective vibration damping
- **NEW** round shaped MDF chassis
- **NEW** spring loaded feet with conical tip adjustable from the top of the turntable chassis
- Heavyweight mass-loaded design
- Magnetically decoupled main platter
- Resonance-optimised alloy
- Inverted main bearing with ceramic ball
- Flywheel belt drive
- High gloss hand-polished aluminium surfaces
- Handmade in Europe

<b>Speed:</b> 33, 45 electronic speed change
<b>Speed variance:</b> 33: ±0.09% 45: ±0.08%
<b>Wow and flutter:</b> 33: ±0.01% 45: ±0.01%
<b>Signal to noise:</b> -75dB
<b>Effective tonearm mass/length:</b> 21.7g/ 12" (304.8mm)
<b>Overhang:</b> 13.2mm
<b>Actuation principle:</b> Flywheel belt drive
<b>Motor control system:</b> Precision generator
<b>Platter:</b> 10,55 kg magnetically decoupled
<b>Main bearing:</b> ceramic (ball/plate)
<b>Tonearm:</b> 12" aluminium - 3-point pivot
<b>Dimensions:</b> 580x 220 x 480mm (WxHxD)
<b>Power consumption:</b> 15W/0.5W standby
<b>Power input:</b> 15V/ 1.6 A DC, universal power supply
<b>Weight/incl. packaging:</b> 37 kg/60 kg

## Pro-Ject's Flagship Signature

After showing off various early **design-concepts** of this turntable at audio shows worldwide over the past couple of years, we're more than excited to officially introduce our new flagship turntable, the **Signature 12.2**.

Pro-Ject Audio Systems is not typically associated with the **ultimate of high-end turntables**. But our goal has always been to make **high-end technology more affordable**. To **really understand what high-end means**, we've always been **working on different high-end turntable technologies to improve our reference-designs** so we can create spin-offs for more **affordable record players**.

That's why we created the **Signature** line! We're thrilled to offer these turntables at an **extremely attractive price**, as the **development cost is not counted**, as we anyway had to do the **research to move forward with Pro-Ject technology** in general. The new **Signature 12.2** is now even **more impressive** than its predecessor!

## The ultimate in craftsmanship

The Signature 12.2 represents highest level of turntable technology with **exclusive materials** and **luxury finish**. The turntable is **handmade** only by our **best trained people!** All metal parts are **hand polished** and there are about **100 different CNC parts** used - **all made in house**.

**Note**, it takes about **2 days to hand-polish** and **precision-mount all the components**, and all components are **manufactured in-house**.

The **heavy MDF main chassis** is **hand-painted in 10 layers** and carefully **hand-polished** to achieve the **classic, timeless and luxurious piano-black finish**. The main chassis is **bigger and more massive** than before, plus the **new rounded edges reduce standing waves**. With precision CNC machining we **avoid hollow spaces** wherever possible, **eliminating any unwanted resonances**.



## Bearing and Platter

To ensure stable speeds a proper platter bearing is needed. The Signature 12.2 uses a **special technology**.

The **heavyweight platter** spins on an **inverted ceramic ball bearing** with a **magnetic support** to **reduce bearing noise and resonance to an absolute minimum**.

The main platter is **precision CNC-machined** from aluminium and weighs a **substantial 10.5kg**. Taking this base, we've glued **recycled vinyl records** to the top (which act as a **perfect mat**) and **bake this 'sandwich'** before **precision balancing** it.

With this solution the final product benefits from a **wonderfully resonance-free**, heavy platter and with the **magnetic decoupling** we are able to **relieve the main bearing** and ensure that the platter runs **ultra-silently**.

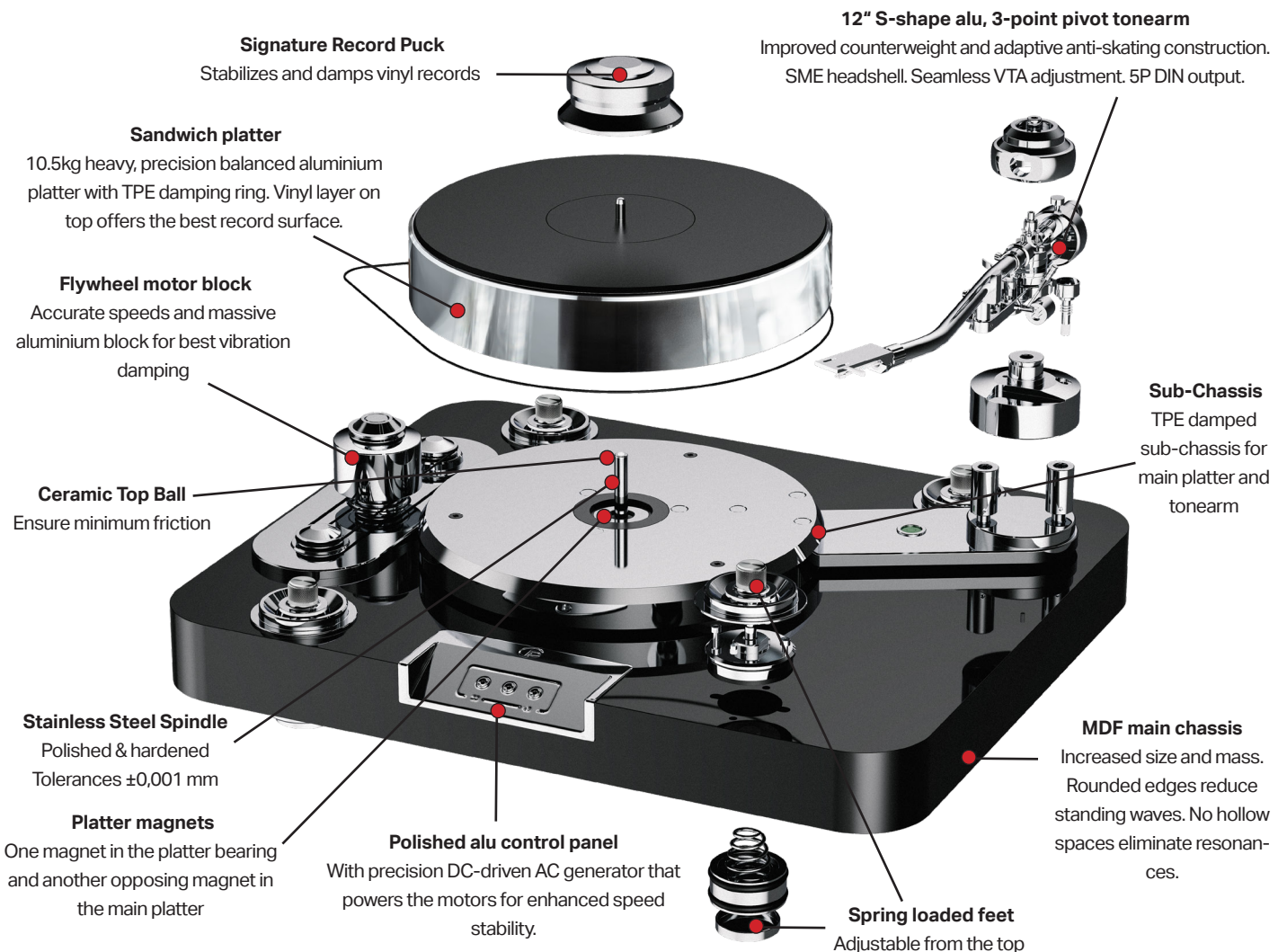
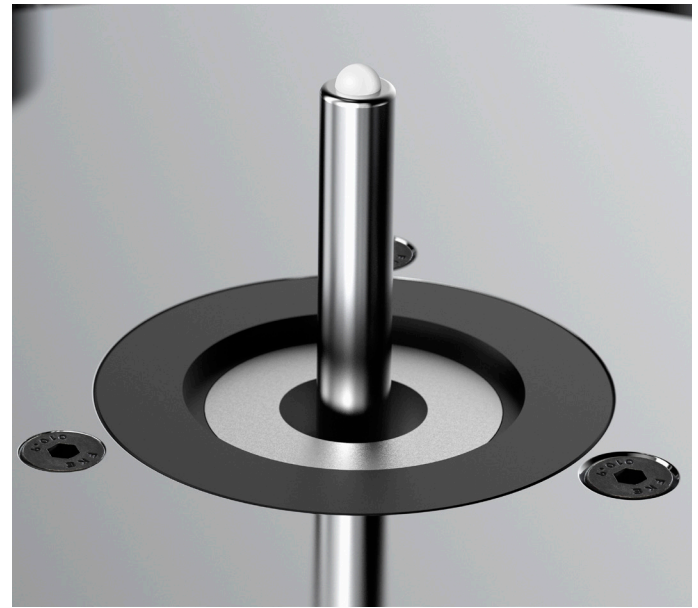

## Tonearm Design

The new **12" S-shape aluminium tonearm** has received **several new innovations**. Two of the more subtle changes include **improvements to the counterweight and the anti-skating**. The counterweight now features a fine thread for **smoother tracking force adjustment**, allowing for smaller, more incremental changes.

## Adaptive Anti-Skating

The anti-skating philosophy has remained the same. Our **correct adaptive anti-skating mechanism** adjusts the anti-skating to **accurately reflect the force** required between the **inner and outer grooves** of the vinyl record. We have fine tuned the position of the mechanism on the tonearm to make it **more accessible and therefore easier to setup**.



## Sub-Chassis

**Sub-Chassis** designs are more commonly found in **light-weight turntables**. They are incredibly effective in **isolating the turntable**, especially if it is placed in very close proximity to the speakers.

However there are certain elements of sub-chassis design that lend themselves **exceptionally well to be used in high-mass turntables**.

In the Signature 12, the **tonearm and platter** are mounted on a **TPE decoupled, resonance optimized aluminium alloy sub-chassis**, another step towards separating tonearm and platter from the mass & spring loaded main chassis and the motorblock.

The tonearm is equipped with an easily accessible **5P DIN connector** on the back of the base and remains fully **VTA adjustable** on the fly, just by turning a set screw. Finding the right VTA could not be more intuitive.

### 3-point pivot tonearm bearing

The most significant change is in the tonearm bearing. We have **redesigned** the tonearm bearing to switch from a uni-pivot to a **3-point pivot system**. The uni-pivot system is an **excellent solution** that is **widely used in high-end tonearms**. However, there are also some disadvantages. They are very **costly to produce** and can often be **difficult to set up**. The entire tonearm **weight is supported by a single pin**, which **exerts significant stress** on it. Therefore, **material selection, design, and manufacturing** must be carefully considered to ensure the viability of this system.

Our research has demonstrated the **effectiveness of cardanic 4-pin point bearings** in managing the weight and load of a tonearm. This has led us to **experiment with adding a additional pivot points** to our uni-pivot design. **Precise alignment** of the three pivot points results in **further reduction of friction and enhanced stability, outperforming cardanic** or our previous **unipivot bearings**. The ability to **track the most minute changes** in the grooves of your vinyl records and **extract the utmost detail** has been improved by yet another step.

The new bearing design will also **accommodate heavier high-end MC cartridges** more efficiently than before.

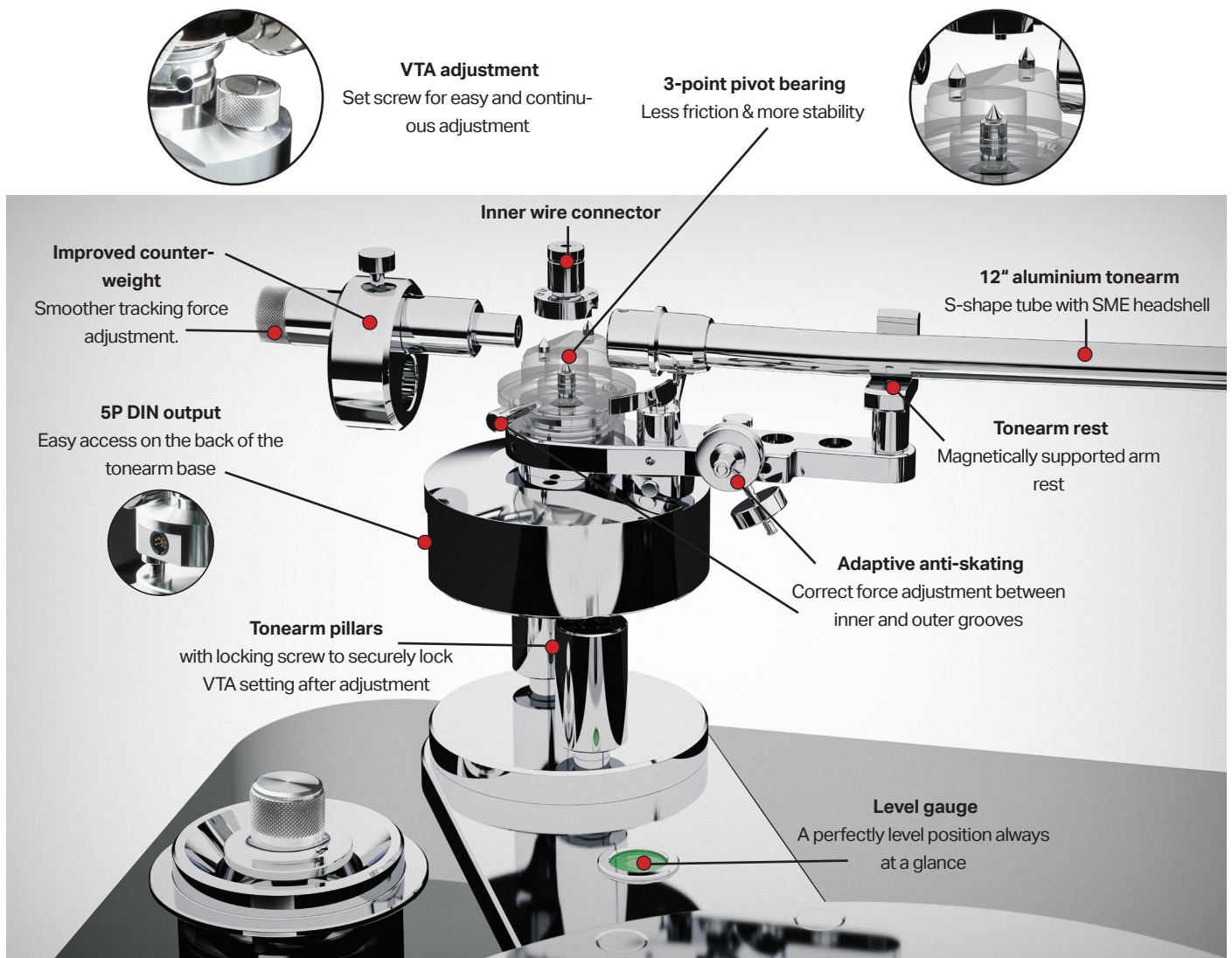

## Spring loaded feet

In order to accommodate the **increased total mass** of the Signature 12.2 compared to its predecessor, we have designed completely new **spring-loaded feet**.

In the case of **ultra-high mass**, as seen in the Signature 12.2, our research has shown that the **current magnetic feet are not strong enough**. The new **spring-loaded feet** provide a **superior decoupling effect** for the turntable. Additionally, this enables us to modify the damping characteristics and construct a **mass-loaded sub-chassis**.

The feet use **conical tips** to **redirect any unwanted energy** (vibration, resonances, noise, etc.) away from the turntable. They are easily **adjusted** from the top of the chassis, allowing for a **level position** to be achieved with minimal effort.

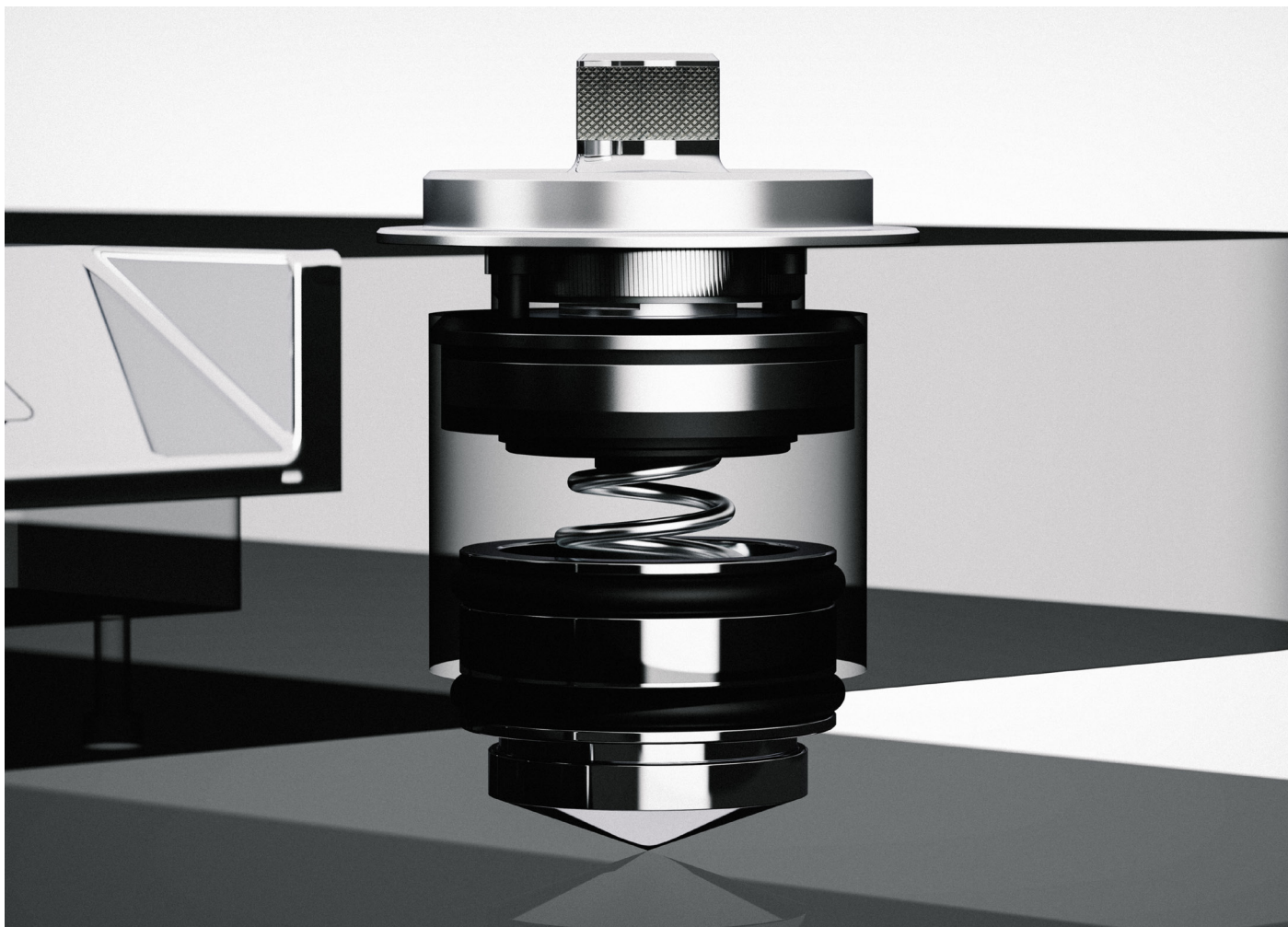



## Motor block and Flywheel

The Signature 12.2 uses the same drive principle as before. Its **flywheel belt drive** system ensures a **vibration-free running** which results in the most accurate and stable speeds.

The motors are now **mounted in a full aluminum motor block**, which further **dampens vibrations**. Aesthetically, the new motor block adds additional **high-gloss polished aluminum accents**, enhancing the overall **visual appeal** of the complete Signature 12.2 package. An **elegant and luxurious finishing touch**.

## Electronic Speed Control

The motor is powered by a precision **DC-driven AC generator** for playback speeds of 33 and 45 RPM with the **utmost precision**.

After careful consideration, we have decided to forego the old display in favor of an **elegant control** panel crafted, again, from **hand-polished aluminum**. Displays inherently have the disadvantage of producing unwanted (and unnecessary) **electromagnetic radiation**. Removing the display is not only a **commitment to the analogue and haptic control elements** that bring **joy to use**, but also a **commitment to focus solely on audio quality**.



## High-end phono cable

Cables are not able to make your sound system sound better, but they ensure that **every detail and information of the signal** is transmitted to the dedicated receiving device.

The included **Connect it Phono DS 5P/RCA** is a high end phono optimized cable. With quality **99.99% OFC copper** conductors and **silver plated connectors** for a lossless signal transmission.

### Upgrade to TRUE BALANCED



Use your Signature 12.2 in balanced configuration with our **Phono Box RS2** to ignite the full potential!

To do so, get your **True Balanced cable** now!

Contact your dealer for more information or go to:

[www.project-audio.com/connect-it](http://www.project-audio.com/connect-it)



*\*To use our True Balanced Connection, your Signature 12.2 needs to be equipped with an MC cartridge.*

