

Power⁵

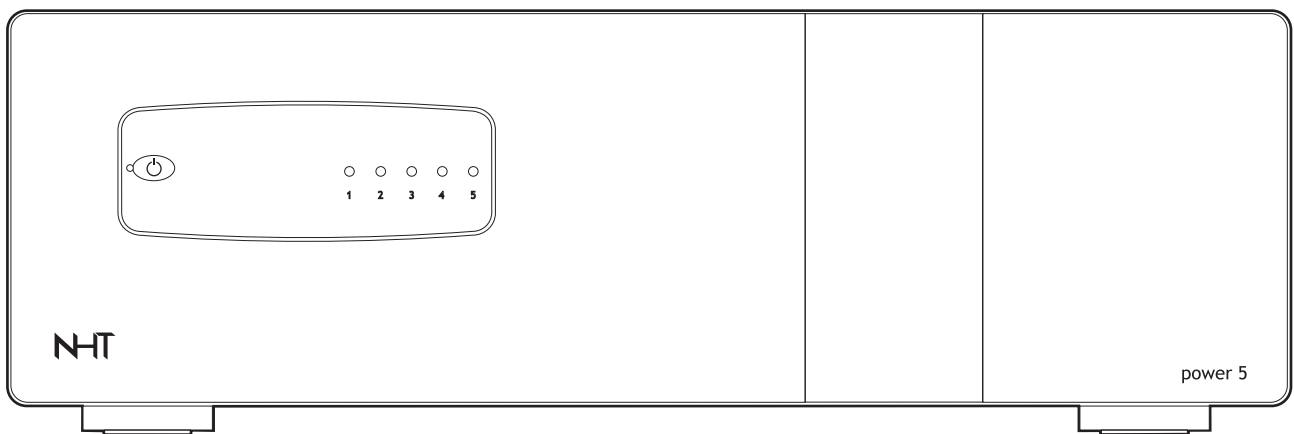

user guide



**WARNING: TO REDUCE THE RISK OF FIRE OR ELECTRIC SHOCK,
DO NOT EXPOSE THIS APPLIANCE TO RAIN OR MOISTURE.**

WARNING: THIS APPARATUS MUST BE EARTHED.



CAUTION: TO REDUCE THE RISK OF ELECTRICAL SHOCK, DO NOT REMOVE COVER. NO USER-SERVICEABLE PARTS INSIDE. REFER SERVICING TO QUALIFIED PERSONNEL.



The lightning flash with arrowhead symbol, within an equilateral triangle, is intended to alert the user to the presence of uninsulated "dangerous voltage" within the product's enclosure that may be of sufficient magnitude to constitute a risk of electric shock to persons.



The exclamation point within an equilateral triangle is intended to alert the user to the presence of important operating and maintenance (servicing) instructions in the literature accompanying the appliance.



Marking by the "CE" symbol (shown left) indicates compliance of this device with the EMC (Electromagnetic Compatibility) and LVD (Low Voltage Directive) standards of the European Community.

This equipment has been tested and found to comply with the limits for a Class B digital device, pursuant to Part 15 of the FCC Rules. These limits are designed to provide reasonable protection against harmful interference in a residential installation. This equipment generates, uses and can radiate radio frequency energy and, if not installed and used in accordance with the instructions, may cause harmful interference to radio communications. However, there is no guarantee that interference will not occur in a particular installation. If this equipment does cause interference to radio or television reception, which can be determined by turning the equipment on and off, the user is encouraged to try to correct the interference by one or more of the following measures:

- Reorient or relocate the receiving antenna;
- Increase the separation between the equipment and the receiver;
- Connect the equipment into an outlet on a circuit different from that to which the receiver is connected;
- Consult the dealer or an experienced radio/TV technician for help.

Important Safety Instructions

- **Read These Instructions**
- **Retain These Instructions**
- **Heed All Warnings**
- **Follow All Instructions**
- **Water and Moisture** - Do not use this product near water. Do not place any objects filled with liquids, such as vases, on top, above or near the apparatus.
- **Cleaning** - Unplug this product from the wall outlet before cleaning. Do not use liquid cleaners or aerosol cleaners. Clean only with dry cloth.
- **Ventilation** - Do not block any ventilation openings to protect the unit from overheating. This product should not be placed in a built-in installation such as a bookcase or rack unless proper ventilation is provided or the manufacturer's instructions have been adhered to.
- **Heat** - Do not install near any heat sources such as radiators, heat registers, stoves, or other apparatus (including amplifiers) that produce heat.
- **Grounding** - Do not defeat the safety purpose of the polarized or grounding-type plug. A polarized plug has two blades with one wider than other. A grounding type plug has two blades and a third grounding prong. The wide blade or the third prong are provided for your safety. If the provided plug does not fit into your outlet, consult an electrician for replacement of the obsolete outlet.
- **Power Cord Protection** - Protect the power cord from being walked on or pinched particularly at plug, convenience receptacles, and the point where they exit from the apparatus.
- **Lightning and Periods of Non-Use** - For added protection for this product during a lightning storm, or when it is left unattended and unused for long periods of time, unplug it from the wall outlet.
- **Servicing** - Do not attempt to service this product yourself as opening or removing covers may expose you to dangerous voltage or other hazards. Refer all servicing to qualified service personnel. Servicing is required when the apparatus has been damaged in any way, such as when a power supply cord or plug is damaged, liquid has been spilled or objects have fallen into the apparatus, the apparatus has been exposed to rain or moisture, does not operate normally, or has been dropped.
- **Accessories** - Only use attachments / accessories specified by the manufacturer.
- **Overloading** - Do not overload wall outlets, extension cords, or integral convenience receptacles as this can result in a risk of fire or electrical shock.
- **Power Sources** - This product should be operated only from the type of power source indicated on the marking label.

Table of Contents

Safety Information	2
Getting started	
Introduction	5
Unpacking	5
Parts List	5
Specifications / Features	6
Placement	6
Connections	
Audio Connections	7
Speaker Connections	8
Control Connections	9
Connections with NHT Controller	10
Power Connection	11
Front Panel	12
Operation	12
Care and Maintenance	12
Troubleshooting	13
Warranty Statement	13

■ Getting Started

Introduction

Thank you for your purchase of the Power⁵ amplifier. Your investment in this product speaks volumes about your uncompromising desire to experience the highest levels of fidelity from your music and movie collection. We could wax poetic about the inaudible noise floor, bandwidth to channel 3 on your television and remarkable phase accuracy of this amplifier. You can read all about the specifications all you wish. While some of us might find that interesting, the real heart of the matter comes when you sit down and listen to your system. We feel we have succeeded at the point when you have long forgotten about the specifications, operating temperature, or even the fact that you have an amplifier connected to your system. All the watts, cables and setup configurations should simply go away, leaving nothing between you and the music.

Before you begin your journey to audio nirvana, we think it's important that you invest a few minutes learning about the proper setup and operation of the Power⁵. This will insure your investment is maximized and the beginning of the bragging rights associated with the pleasure of possessing the most advanced amplifier on the planet. We sincerely wish, that from this point forward, this were the only reason you remember you even own a Power 5 at all! Job done.

If you have any technical questions, please visit nhthifi.com or call **800-NHT-9993**.

Unpacking

Carefully unpack the Power⁵ and inspect all the contents. Store all packing materials for later use, if possible. You will need the packing materials, if you have to ship your Power⁵ unit.

Parts List

- Power⁵ unit
- 12 volt trigger cable
- RJ45 cable for NHTBus
- This user guide
- Power Cord
- Product Registration Card

Specifications / Features

Power Output

- 5 x 200W RMS @ 8ohms THD+N <0.05% - all channels driven simultaneously
- Peak Power 300W into 8ohms any individual channel
- Frequency response +/-0.5dB 20-20kHz
- Dynamic range 100dB A-weighted @ full power
- IM distortion (CCIF) 0.001%
- TIM distortion 0.01%
- Soft Clipping

NHTBus Features

- Intelligent operation with NHT Controller
- Monitoring of amplifier status
- Amplifier control – on/standby/mute
- Control of individual channel operation – on/off
- Utilizes Ethernet infrastructure

Protection features

- Phase-to-phase short
- Phase-to-ground short
- Under voltage
- Thermal protection

Rear panel connectors & components

- 5 Single-ended RCA input connectors
- 5 Pair of binding posts for speaker output – banana spacing
- 12V Trigger input/output on 1/8" sub mini jacks
- NHTBus connector on RJ45
- IEC mains voltage socket

Front panel features

- 5 Dual-color LED's for each channel indicating OK/Fault
- Standby Touch Sensor
- Standby indicator

Placement

The Power⁵ amplifier may be placed on a shelf, or in a standard 19" equipment rack using the optional rack ears and hardware.

Ideally, the Power⁵ should be placed in close proximity to the NHT Controller or surround processor. Minimizing cable lengths reduces the chance of noise pickup.

Note: Due to the placement of the Power⁵ power switch on the rear panel, do not install the Power⁵ in a wooden box or similar enclosure where access to the power switch is blocked or inconvenient.

■ Connections

Audio Connections

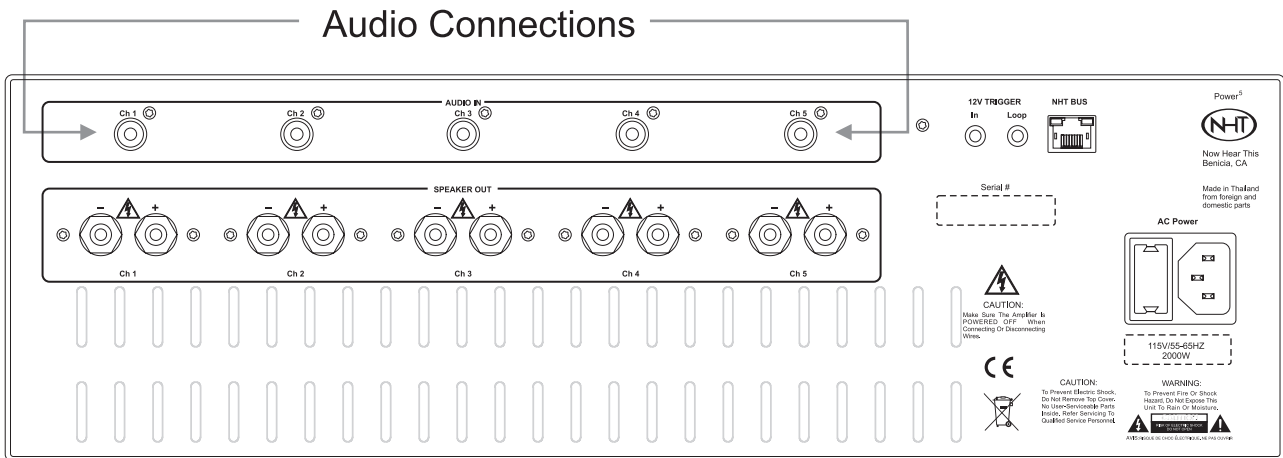

CAUTION: Before connecting anything make sure the Power⁵ and all your other electronic components are turned off.

source material, it switches the Power5's middle 3 channels to standby mode. **NOTE:** See section: Connections with the NHT Controller

Use the highest quality connectors you can afford. Keep all your wires as short as possible and routed neatly to minimize noise problems.

To minimize noise problems, try to segregate wires by function, and separate them by the maximum practical distance. Where audio wires and AC power cords intersect, cross them at right angles.

The Power5 has five inputs. It's best before you set up your system to decide what channels are used for what speakers. Here's a typical 5 channel configuration:

- Channel 1 ----- Left Front
- Channel 2 ----- Left Surround
- Channel 3 ----- Center
- Channel 4 ----- Right Surround
- Channel 5 ----- Right Front

When connected to the NHT Controller and are using the NHT Bus, you need to use this configuration. This is due to the fact that when the controller senses 2- channel

Speaker Connections

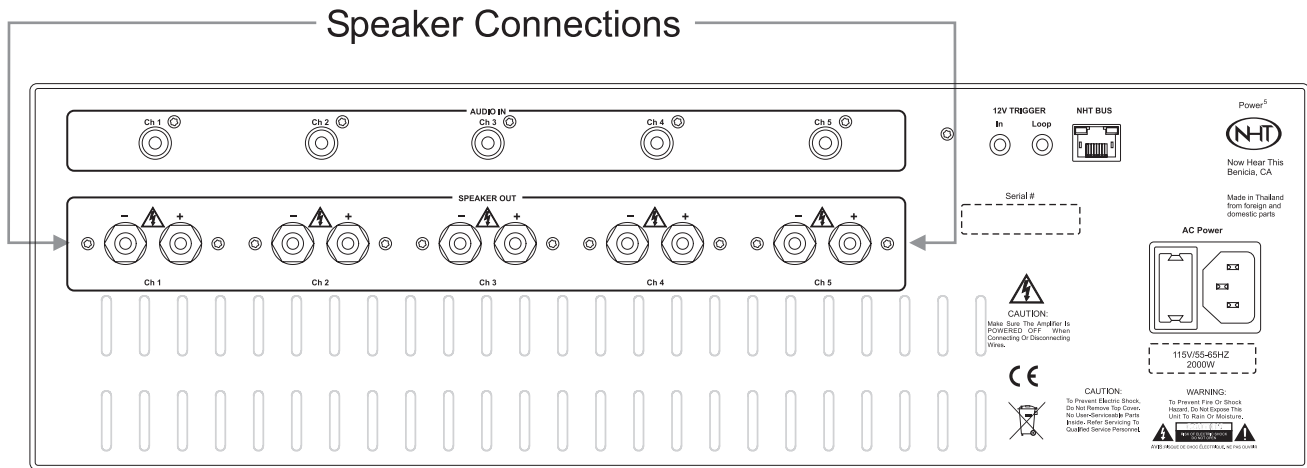

CAUTION: Before connecting anything make sure the Power⁵ and all your other electronic components are turned off.

The minimum gauge speaker wire recommended for runs of 20 feet or less is 14 gauge. Heavier special purpose cable can be used for longer runs. For best results, use equal length runs of cable for the left and right speakers (or for the left, center and right speakers).

For proper response, the speakers must be wired **in-phase** with each other. That is, the Red (+) terminal on the amplifier speaker output must be connected to the corresponding Red (+) terminal on the speaker. The same is true of the Black (-) terminals. All speaker cable or wire has a marking along one or both conductors to help you make the correct connections. Weak bass and the lack of a well-defined image are indications that speakers are wired out of phase. A well-defined image is one in which you can easily locate the positions of performers in the sound field.

The gold plated binding posts on all NHT products will accept raw wire or virtually any type of special purpose terminal. If you plan to use raw wire, strip 1/2" to 3/4" of insulation from the ends, twisting the exposed wire strands tightly.

Loosen the binding post nut on the terminal until the hole is exposed. Slip the wire through the hole in the binding post. Tighten nuts on the binding post until snug. If you use a wrench **DO NOT OVERTIGHTEN** or you may damage the binding post.

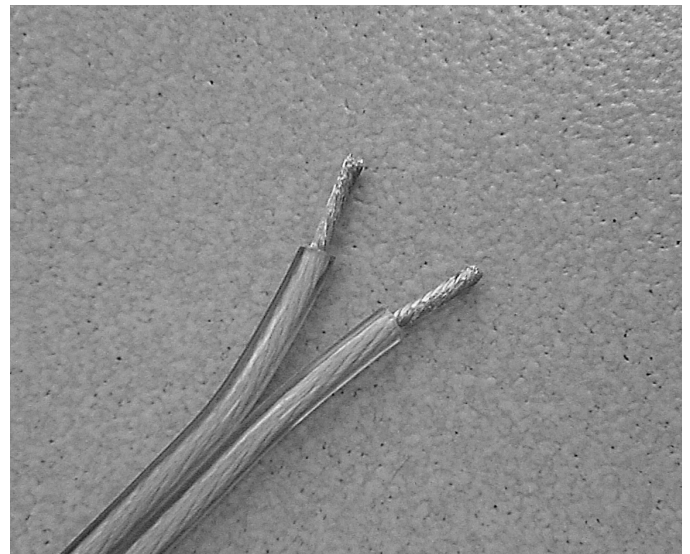

Control Connections

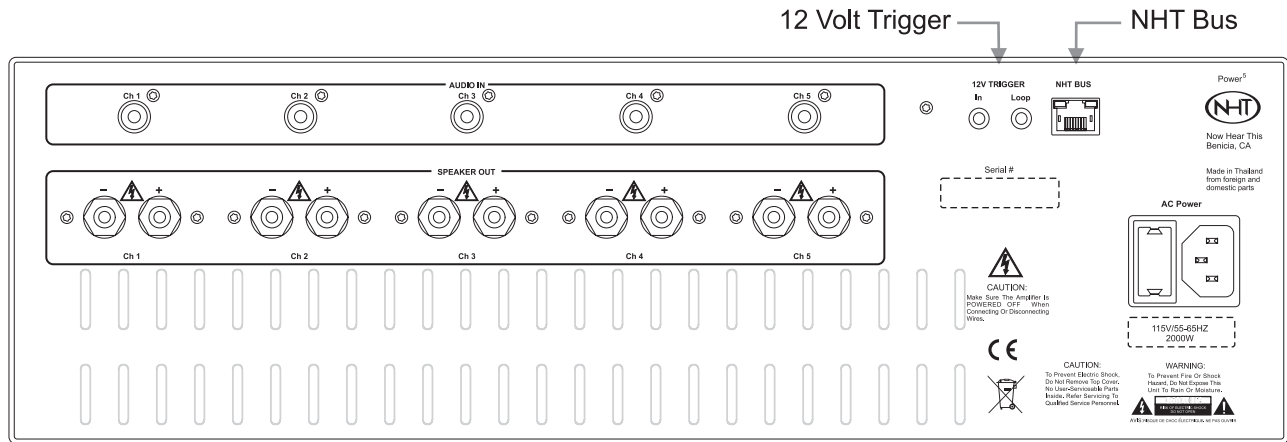

The Power⁵ has both 12 volt trigger connections and the NHT Bus connection. A 12 volt trigger cable is supplied with the Power⁵.

12 Volt Trigger can be used to remotely turn the Power⁵ on or off (in and out of standby mode) when it detects a DC control signal from another component in your system. The external trigger will accept 5 - 24 volt (DC) signals. For more information regarding external triggers, consult your authorized dealer.

The NHT bus connection is an intelligent connection utilizing ethernet infrastructure, using a typical CAT5 connector. When connected to the NHT Controller it controls on/standby/mute, just like the 12 volt trigger. NOTE: when using the NHT Bus, do not use the 12 volt trigger. The Controller can also turn on and off channels when you are listening to five channel surround or just 2 channel stereo. This optimizes the Power⁵'s power supply and reduces heat. The NHT Controller can monitor amplifier status as well. The NHT Bus is an open architecture design so more functions can be added in the future.

Connections with the NHT Controller

Chances are you bought the Power5 with a NHT Controller and possibly NHT speakers. Here's an example of how the system should be connected. See the NHT Controller User Guide for more information on connecting your NHT system.

- Channel 1 ----- Left Front
- Channel 2 ----- Left Surround
- Channel 3 ----- Center
- Channel 4 ----- Right Surround
- Channel 5 ----- Right Front

Controller

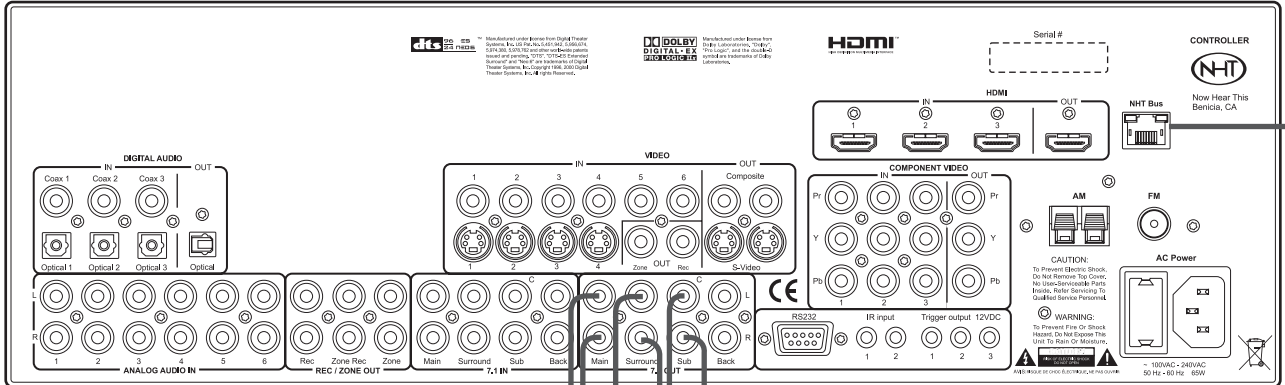

Power5

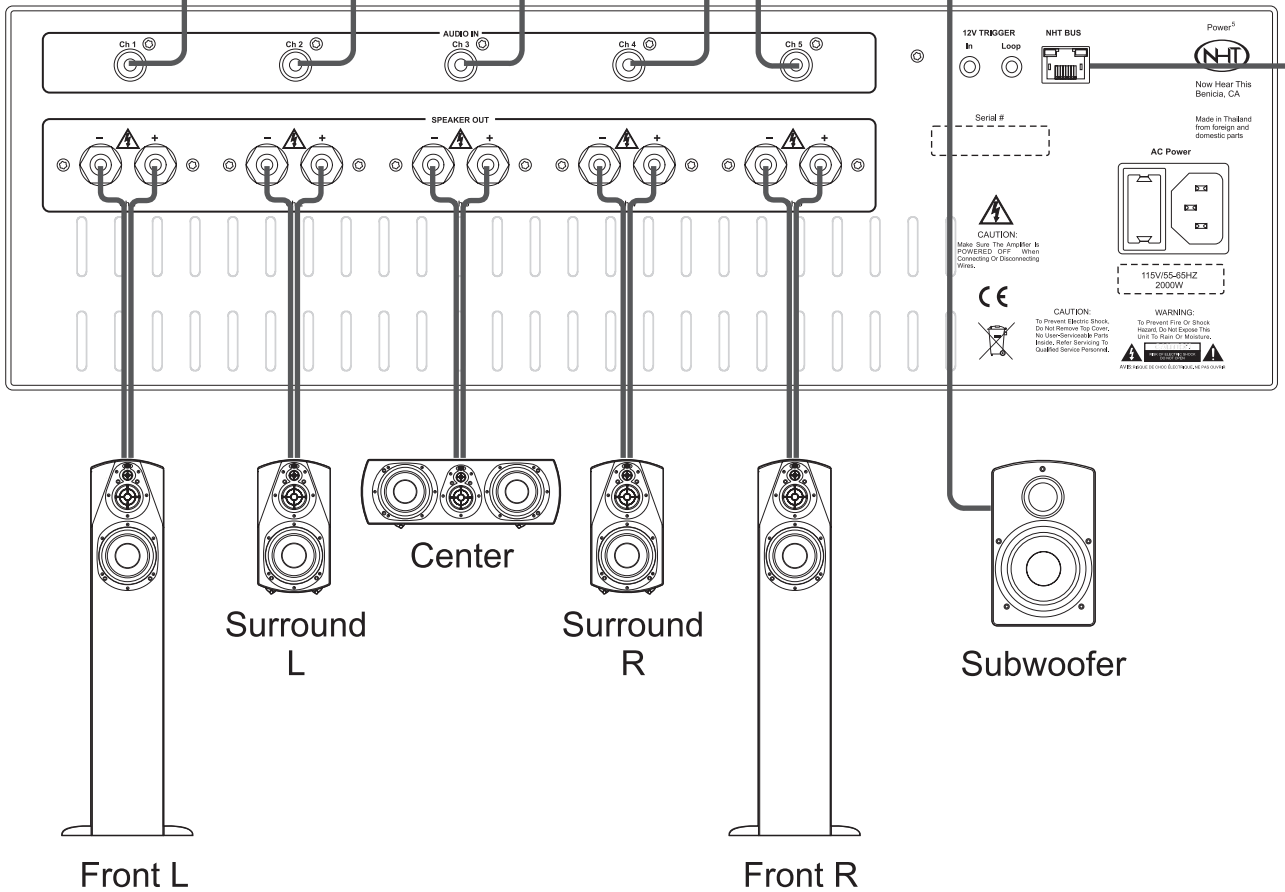

Power Connection

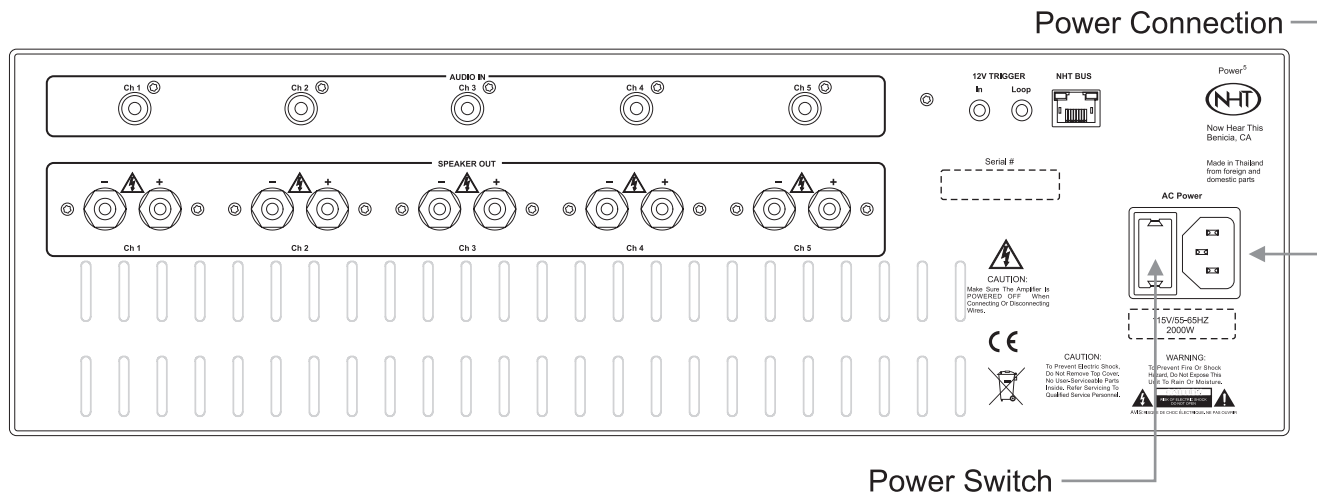

CAUTION: Before connecting anything make sure the Power⁵ and all your other electronic components are turned off.

The Power⁵ amplifier receives power via the detachable IEC style power cord.

Note: Due to the placement of the Power⁵'s power switch on the rear panel, do not install the Power⁵ in a wooden box or similar enclosure where access to the power switch is blocked or inconvenient.

■ Front Panel

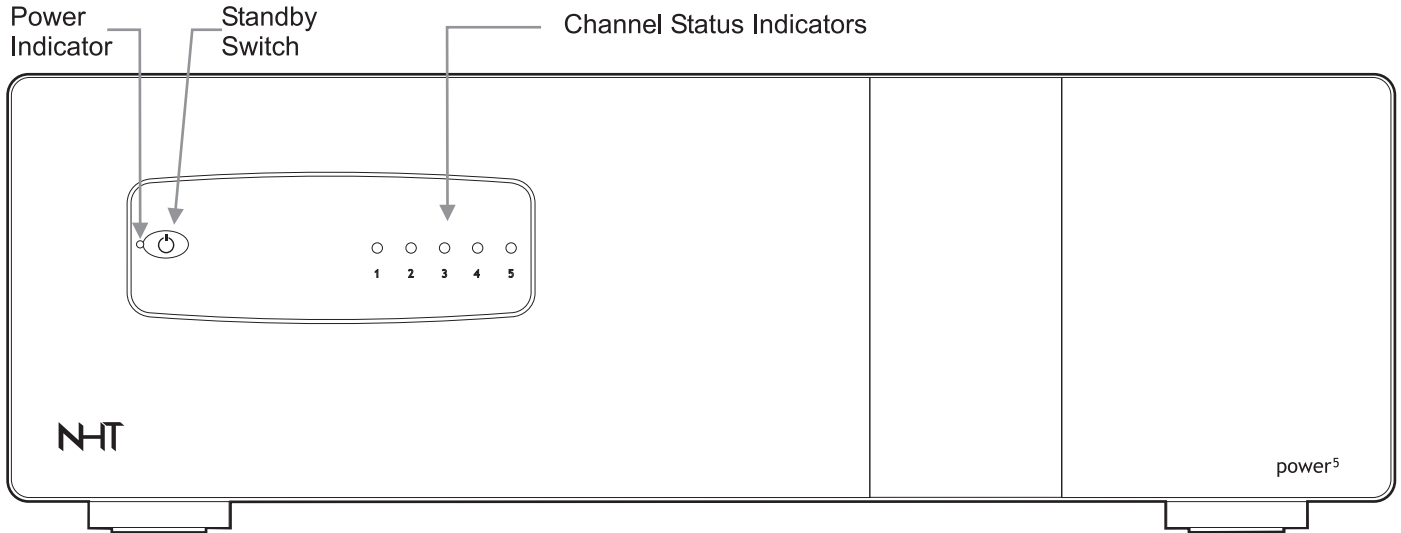

Power indicator - This LED is GREEN when the Power⁵ is on and AMBER when it is in standby mode.

Standby switch - This switch gives front panel access to the standby function. It switches between standby and on.

Channel Status Indicators - These LEDs indicate the status of each of the five channels.

GREEN - the channel is on and working properly.

RED - the channel is in fault condition.

Off - the channel is in standby mode. NOTE: the middle 3 channels will go into standby mode when playing 2 channel source material and connected to the NHT Controller via the NHT BUS. This optimizes the power supply when listening to 2 channel source material.

■ Operation

By now you should have the audio, speaker, control and power connections done. Now you can turn the power switch located on the rear panel to the ON position.

After a brief period, the standby LED should light up and indicate that the unit is in standby mode. Touch the standby button on the front panel to switch the Power⁵ out of standby mode. The LED will change to Green and the Power⁵ is now up and working.

The power switch on the rear panel should be left on all the time, since when in standby mode the Power⁵ draws very little current. Only if you will not be operating the Power⁵ for an extended period of time, you may switch the power off.

■ Care and Maintenance

You may need to dust or clean the Power5 every once in a while to maintain its beautiful finish.



WARNING: Make sure the power cable is unplugged before cleaning.

Never use solvents, they will damage the surface. Only use very soft cloth and very mild soapy water (1/2 ounce of dish soap per gallon of water) on the top, sides and front. Never clean the rear panel this way, this may damage the connectors. Simply dust the rear panel. Let the Power⁵ dry for an hour before returning it to operation.

■ Troubleshooting

Problem	Solution
No LEDs and no Sound	Make sure the power cable is plugged in and the power switch on the rear panel is in the ON position.
No Sound, amber standby LED	If the standby switch is showing an amber LED, press the standby switch. It should change to green and you should have sound.
No Sound, all LEDs green	Check to see if your source and preamp/surround processor is setup properly. Check that the speaker wires are connected properly. Check that the input connectors are connected properly. Try a different loudspeaker.
Status LED is red	Amplifier is running too hot, see if the amplifier placement is blocking Power5's air vents in any way. Check to see if there is a shorted speaker wire.

Limited Warranty Valid Only in the U.S.A. and Canada

Warranty Period

For a period of 3 years for parts and 3 years for labor from the date this product is first purchased from an authorized NHT dealer, Now Hear This (NHT) warrants that if it fails to function properly due to a manufacturing defect, despite its being installed and operated according to these instructions and used under normal conditions, it will be either replaced or repaired with new or rebuilt parts (both at NHT's option) with a unit of comparable value without charge to you.

What's Not Covered

Altered, defaced or removed serial numbers void this warranty.

This warranty does not cover any product used in trade, business, industrial or commercial applications.

This warranty also does not cover the cabinet or appearance factors, or costs, defects or damage resulting from misuse, abuse, accident, improper maintenance, alterations or modifications not authorized in writing by NHT, or parts or labor from any source other than an authorized NHT service location.

Damage due to power exposure in excess of the speaker's published power ratings; ie, overpowering, lightning or power surges, are also not covered.

Your Rights

This warranty gives you specific legal rights, and you may have other rights which vary from state to state.

NHT limits this warranty to the purchase price of the product, excludes incidental or consequential damages, and limits its obligations under any implied warranties under state laws to a period not exceeding their warranty periods. As some states do not allow the above limitations, however, they may not apply to you.

To Obtain Service

To find the name and address of the nearest authorized NHT service location, call or write:

Customer Service Department, NHT, 6400 Goodyear Rd., Benicia, CA 94510, 1-800-NHT-9993 (648-9993), www.nhthifi.com

For your future convenience, please keep this warranty with your sales receipt, and record date and place of purchase for further reference.