



# The Select Digital Director **User Guide**

Check our website for the most recent user guides,  
firmware, and drivers:  
[www.msbtechnology.com](http://www.msbtechnology.com)

Technical support email is:  
[techsupport@msbtechnology.com](mailto:techsupport@msbtechnology.com)

12.13.2022



# Technical specifications

Supported Formats (Input dependent)	44.1kHz to 3,072kHz PCM up to 32 bits 1xDSD, 2xDSD, 4xDSD, 8xDSD Supports DSD via DoP on all inputs
Digital Inputs	4x Advanced isolated input module slots
Controls	12 Volt trigger IR remote control Power button Power control mode switch Display brightness wheel
Fuse	2.5A 250V SLO BLO - 5 mm x 20 mm fuse.
Chassis Dimensions	Width: 17.5 in (444 mm) Depth: 17.5 in (444 mm) Height without feet: 3 in (79 mm) Stack height: 3.625 in (92 mm) Weight: 35 lbs (16 kg) Product Feet: M6X1 Thread
Shipping Dimensions	Width: 23 in (585 mm) Depth: 23 in (585 mm) Height: 7 in (178 mm) Weight: 53 lbs (24 kg)
Included Accessories	Pro ISL input module Pro ISL cable Control Link module Control Link toslink cable User manual IEC power cable 3.5mm Mini jack cable

# Setup and installation

**\*\*\* ATTENTION! \*\*\***

Before installing your new digital director, your DAC firmware must be updated to 3.0.2.1 or later. Otherwise, The Digital Director will not fully function.

## Step 1 - New firmware

If needed, update your DAC firmware to the latest available version. The latest DAC firmware enables new functionality with the digital director. Firmware update files and instructions can be found at:

[www.msbtechnology.com/Support](http://www.msbtechnology.com/Support)

## Step 2 - Swap digital input modules

**\*\*\*POWER OFF YOUR AUDIO SYSTEM\*\*\***

Install the provided Pro ISL input module into slot 'B' of your DAC and install the provided Control Link module into slot 'A'. Then, install any other digital inputs from your DAC into your Digital Director. When installing and removing input modules please use the tips below for proper handling to reduce risk or damage to your MSB system.

### About the 4 input module slots

The Digital Director has four input module slots. They are labeled A through D. Digital input modules can be placed in any position. However, the control link module and Pro ISL input module in your DAC must be installed in slot A and B. Each module is completely self contained. It is recognized by the Digital Director and identified on the DAC display.

### Removing and Installing Modules

Removal and installation of modules is a completely tool free process that is easily performed at the back of the unit. Under the lower lip of each module is a lever arm. Simply pull the lever out and away until it is perpendicular with the back of the unit. Then gently, but firmly, pull the module lip and lever until the module releases and slide it out of the unit.

### Module Handling

It is important that you refrain from touching the circuit board or rear connector of any input module when removing or installing any input from your unit. When handling these modules it is important that you only contact the metal case of the module or the front edge of the module where the cam arm is located. Improper handling of your modules can result in static shock and damage to the module or unit.

## Step 3 - Connect your 12 volt trigger

After placing your Digital Director into your system, link the unit to one of your existing MSB powerbase units with the provided 3.5mm mini jack cable. Then set the power control switch on the bottom of the unit to the "Linked" position. This allows the primary powerbase of your system to control the secondary one as well as the Digital Director without them having to be turned on/off separately.

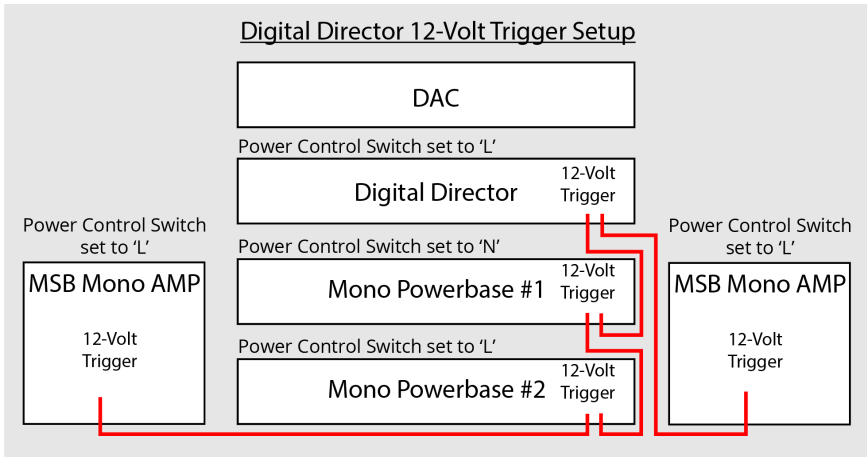

The diagram above is only a visual example and the actual connections may vary in your system. The specific order in which the units are connected does not affect how the 12 volt connections will function. The only requirements are that each unit is connected to a 12 volt trigger port of another unit in the chain. Only one unit is set to the normal 'N' position while all other units are set to the linked 'L' position.

The unit that is switched to the 'N' position will be the main control unit that will receive any power commands sent via the MSB remote or by the power button located on the front of the unit. Any of the units connected via the 12 Volt trigger connections and set to the 'L' position will power on and off only when the main control unit is used. The remote IR and button inputs will be deactivated.

## Step 4 - Make cable connections

After swapping your input modules, the last step is to make a few connections. A description of each connection can be found in the table below as well as a detailed connections diagram on the following page.

Power	The Digital Director has a built-in high performance power supply. The power supply automatically detects and switches between 240V and 120V. This is not a switching supply that works at any voltage, but a linear supply with automatic switching of the transformer leads. The unit is switched on and off with a button on the front or via the IR remote. Plug in the provided AC cable to the back of the unit.
Input Modules	The Digital Director comes with a Pro ISL Input Module and a MSB Control Link Module. Simply remove the digital input modules from your DAC and swap them with the modules in your Digital director. Connect your digital input(s) to the appropriate module(s) in the digital director. The frequency and bit depth of the incoming signal will be displayed on the front panel of your DAC.
Pro ISL Output	Connect the Pro ISL output from your Digital Director to the Pro ISL module in your DAC.
Control Link	Connect the Control Link connector from your digital director to the control link module in your DAC

For a detailed video containing instructions for setup, usage, and more information about the digital director, use your smartphone or tablet camera to scan the QR code below.

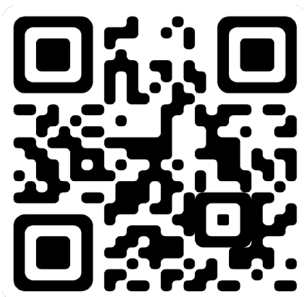

<https://youtu.be/B5esPvxMXo8>

# The Select Digital Director

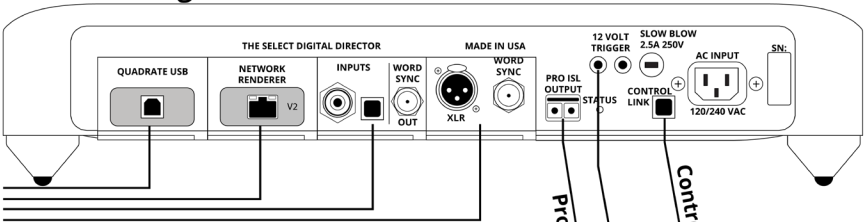

Digital inputs

# The Select DAC

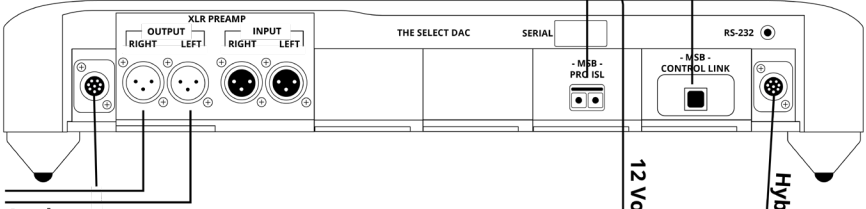

Analog outputs

# The Select Powerbase

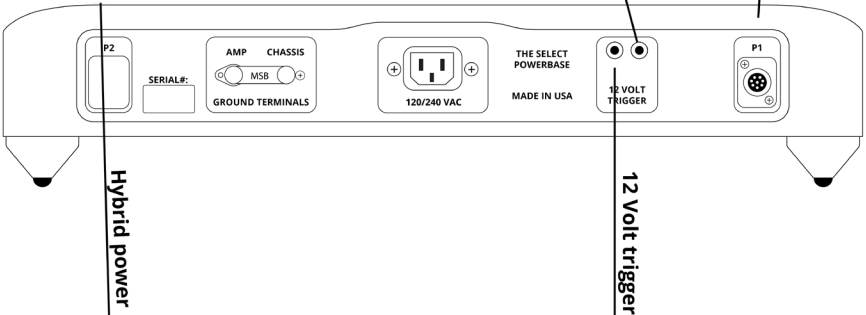

# The Select Powerbase

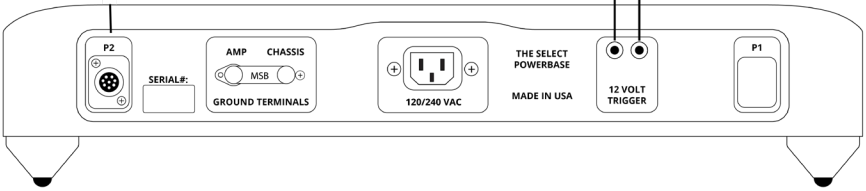

When installed properly, your system should look like the example above. The digital inputs installed in your digital director may vary depending on what sources are in your system, However; the only modules that should be installed in the DAC will be the provided Pro ISL and Control Link modules as well as any analog input modules you may have in your system.

# Digital Director interface

There is one button on the front of the unit as well as two control features just under the front of the unit on the bottom.

LED indications	<p><b>White</b> - Power on.  <b>Red</b> - Power off.  <b>Amber</b> - Linked mode, 12 volt trigger controlled.  <b>Flashing Amber</b> - Over-voltage protection.</p>
Display brightness	This is a rolling wheel to control the brightness of the power indication light
Power control	<p><b>Normal</b> - This sets the unit as the 12 volt trigger master.  <b>Linked</b> - This sets the unit as the 12 volt trigger slave.          The 'master' unit will control this unit.</p>

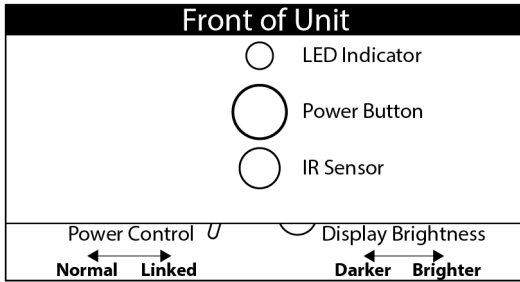



# Digital Director menu options

The following menu options will be viewable in your DAC menu when a digital director is detected in your system. The Digital Director needs to be set to the '*passthrough*' setting whenever you are updating the firmware in your DAC with the digital director connected.

## Select DAC

Digital Direct	<b>Passthrough</b> - Enabled Bit perfect passthrough of files directly to the DAC. <b>Filter (default)</b> - Adds digital filtering and optimization.
----------------	--

## Reference and Premier DAC

Direct	<b>Pass</b> - Enabled Bit perfect passthrough of files directly to the DAC. <b>Filtr (default)</b> - Adds digital filtering and optimization.
--------	--

# Technical Support

If you are experiencing any issues with your MSB product, please contact your nearest dealer or try our support page at [www.msbtechnology.com/support](http://www.msbtechnology.com/support). Please be sure you have the most current edition of your products firmware installed. If your issue persists please feel free to contact MSB directly. Emails are usually responded to in 24 - 48 hours.

**Email:** [techsupport@msbtechnology.com](mailto:techsupport@msbtechnology.com)

## MSB Return Procedure (RMA)

If a customer, dealer, or distributor has a problem with an MSB product, they should email tech support before sending anything back to the factory. MSB will do their best to respond within 24 hours. Should it be clear that a product must be returned, tech support should be informed and all the following relevant information should be provided:

1	Product in question
2	Serial number
3	Exact configuration when symptom is observed along with a list with the input used, source material, system connections, and amplifier
4	Customer name
5	Customer shipping address
6	Customer phone number and email
7	Special return shipping instructions

MSB will issue an RMA number and create an invoice with all details outlined except the final price as the product has not yet been seen. This invoice will be emailed so all the above information can be checked and verified by the customer.

The product should be returned with the RMA number present on the box. Work can then begin immediately and the product can be sent back quickly.

Any repair that is difficult and cannot be completed in two weeks will be identified and the customer will be informed when it is to be expected. Otherwise the majority of repairs should be shipped back within two weeks if all the required information is present on the invoice.

**Link to page:**

<http://www.msbtechnology.com/support/repairs/>

# The Digital Director Limited Warranty

Warranty includes:

- MSB warrants the unit against defects in materials and workmanship for a period of **1 year** from the date the unit was originally shipped from MSB.
- This warranty covers parts and labor only, it does not cover shipping charges or tax/duty. During the Warranty period, there will normally be no charge for parts or labor.
- During the warranty period, MSB will repair or, at our discretion, replace a faulty product.
- Warranty repairs must be carried out by MSB or an authorized dealer. Please contact your dealer if your unit requires service.

Warranty excludes:

- The Warranty does not cover standard wear and tear.
- The product is misused in any way.
- Any unauthorized modifications or repairs were performed.
- The product is not used in accordance with the Operating Conditions stated below.
- The product is serviced or repaired by someone other than MSB or a authorized dealers.
- The product is operated without a mains earth (or ground) connection.
- The unit is returned inadequately packed.
- MSB reserves the right to apply a service charge if the product returned for warranty repair is found to be operating correctly, or if the product is returned without a returns number (RMA) being issued.

Operating Conditions:

- Ambient temperature range: 32F to 90F, non-condensing.
- The supply voltage must remain within the AC voltage specified on the power base.
- Do not install the unit near heat sources such as radiators, air ducts, power amplifiers or in direct strong sunlight. This may cause the product to overheat.