

1237A and 1238A

Operating Manual
Genelec 1237A and 1238A
Smart Active Monitors

GENELEC®



Genelec 1237A and 1238A Operating Manual

Introduction

Congratulations and a thank-you for the purchase of this Genelec Smart Active Monitoring (SAM) Series DSP monitor loudspeaker.

This product should be set up using the fully automatic process in the Genelec Loudspeaker Manager GLM™ software. There are no setup controls on the amplifier panel.

This manual describes the basic setup of the monitor for use with the GLM software, as well as use in the Stand-alone mode without the GLM software in use or permanently connected for computer control.

Each monitor is supplied with a mains cable, one GLM control network cable, and an operating manual.

System

The Genelec 1237A and 1238A are three-way monitoring systems for medium sized control rooms. They perform well as free-standing monitors as well as flush-mounted in control room walls. They are suited for recording, film and video post-production, broadcast monitoring as well as for mastering.

The unique Directivity Control Waveguide™ (DCW™) technology by Genelec provides excellent stereo imaging and neutral frequency response even in difficult acoustics.

With program material at a 2 meter listening distance, the fast low distortion amplifiers drive a stereo system to peak sound levels in excess of 122 dB SPL (1237A) or 124 dB SPL (1238A).

The 1237A and 1238A are fully compatible with Genelec Loudspeaker Manager GLM™ and proprietary Genelec control network. They can be used with 8200-series SAM monitors and 7200-series SAM subwoofers in the same network.

Drivers and Cabinet Construction

The 1238A reproduces low frequencies with a 385 mm (15 in) woofer in a 110 litre bass reflex enclosure. The 1237A features a 305 mm (12 in) woofer in a 65 litre bass reflex enclosure. Both monitors use the same proprietary 130 mm (5 in) direct radiating mid-range driver, and a 25 mm (1 in) metal dome tweeter, both acoustically loaded by the proprietary Directivity Control Waveguide. All drivers are magnetically shielded.

Amplifiers and Signal Processing

The 1237A and 1238A use the RAM-L amplifier unit. The RAM-L is mounted with vibration absorbers in the rear of the monitor enclosure, and can also be detached and mounted to a 19 inch rack. Digital signal processing in the RAM-L amplifier unit is done with high precision algorithms, and includes driver and amplifier overload protection. The room response compensations include highly flexible parametric filters, level alignment, and acoustic delay compensation. These allow accurate matching to all console output sections and room acoustics.

Mounting Considerations

Place monitors so that their acoustic axes are aimed towards the listening position (see Figures 1 and 2). Place monitors with left-right symmetry and at an equal distance from the listening position. Acoustic reflections from objects close to monitors and the listening position can cause colouration and blurring of the sound image. Symmetrical positioning of reflective objects maintains good stereo imaging. When soffit (flush) mounting, the wall surface should extend to the monitor, forming a continuous surface.

Minimum Clearances

The minimum clearance is 5 cm (2 in) behind, above and on both sides of the monitor, when the RAM-L amplifier is mounted on the enclosure. The ambient temperature around the amplifier must not exceed 35 degrees Celsius (95°F). When soffit mounting, sufficient ventilation should be arranged behind the monitor. This may require forced ventilation around the RAM-L amplifier.

When the RAM-L amplifier is mounted in a 19 in rack, the minimum free space is 1U both above and below the amplifier and both sides of the amplifier fully open to enable free movement of air. Use the included rack mount front plate to ensure sufficient space above and below the amplifier.

When the RAM-L is mounted on a table, shelf or similar solid surface, there must be a free space of at least 250 mm (10 in) above and 10 cm (4 in) on both sides of the ampli-

fier. Free air flow must be possible in the front side of the amplifier.

Set-up and Use

Monitor calibration and setup

The 1237A and 1238A are set up using the GLM software. The setup is fast and consists of the following steps:

1. Run a CAT5 (RJ45) cable from the monitor control network to the next monitor.
2. Run the final cable to control network input of the GLM Adapter device.
3. Connect the GLM Adapter device to your computer USB connector. The cable is a part of the GLM User Kit.
4. Place the Genelec measurement microphone at the listening location of the engineer, on a stand, with the microphone pointing upwards and the microphone top at the height of the engineers ear in normal working position. The microphone is a part of the GLM User Kit.
5. Run the microphone cable to the microphone input in the GLM Adapter device.
6. Download GLM software at the Genelec web site (www.genelec.com). Install the GLM software.
7. Follow the GLM software instructions to measure and set up your monitors.
8. If you plan to not use a computer for controlling the monitors, use the GLM software to write the setting into the monitors ("Store the Settings").

Recommendations for AES/EBU Audio

For a digital input signal of -30 dB FS, the 1237A and 1238A monitors will produce a 100 dB sound level (SPL) at 1 meter distance, in free space. The sensitivity of the monitor system is set using the GLM software.

It is advantageous to keep the maximum incoming digital audio signal level high, near to 0 dBFS. It may be useful to lower the internal GLM level control. This enables maintaining high digital resolution in the digital source.

Single-wire mode of AES/EBU is the default and the older dual-wire mode is automatically detected if used at the source.

The standard AES/EBU cable carries two channels of audio, called A and B. As a default,

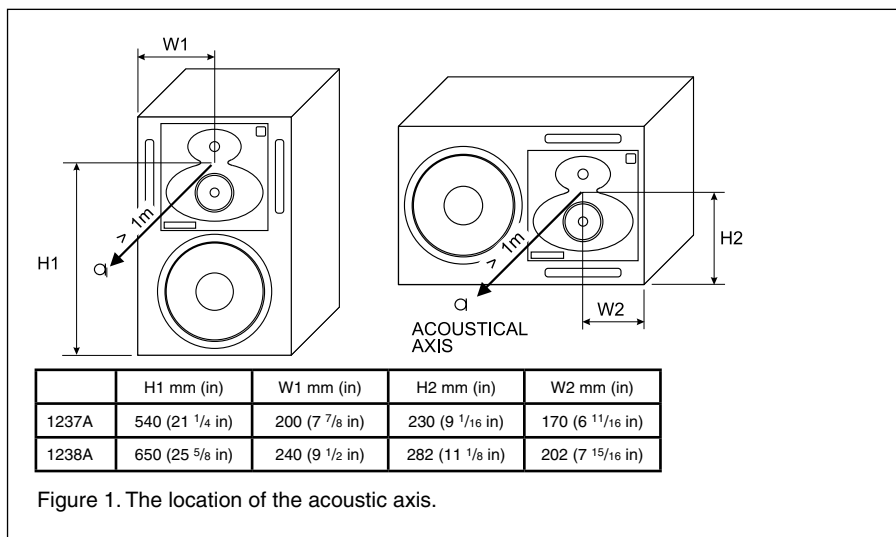

Figure 1. The location of the acoustic axis.

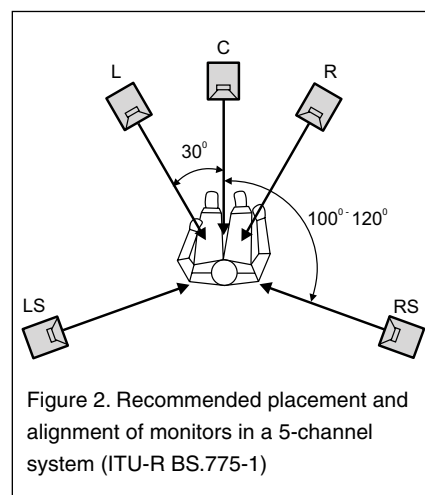

Figure 2. Recommended placement and alignment of monitors in a 5-channel system (ITU-R BS.775-1)

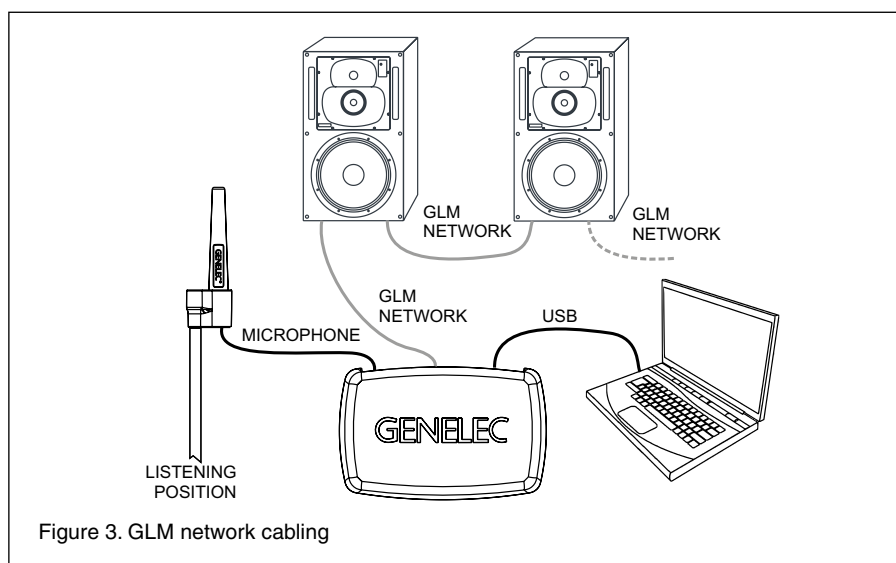

Figure 3. GLM network cabling

both A and B subchannels are reproduced by the monitor. GLM software is used to set up the monitor to specific channel assignments.

RAM-L Amplifier Power Button

The power button in the middle of the RAM-L amplifier front panel controls several functions.

A short press of the power button turns RAM-L on or off. Turning on, the power button light flashes rapidly, and lights on steadily when the turn-on has been completed.

Testing modes are explained later in this manual.

Setting ISS™

The Intelligent Signal Sensing (ISS) puts the monitor to a power-saving stand-by mode automatically. The factory setting for ISS is "OFF." The ISS can be activated using the

GLM software (see Figure 5). When ISS is active, if no audio signal is sensed during the selected time, the monitor powers down. The monitor will power up again once a signal is detected. The ISS setting is applied to all ISS-enabled monitors in the currently selected Setup.

Connections

“MAINS INPUT” Connector

Connect to the mains supply.

“DIGITAL IN AES/EBU” Connector

The monitor defaults to reproducing an analog input signal. The digital audio AES/EBU input is selected automatically when a valid digital audio signal is presented. Use GLM software to define the AES/EBU sub-frame to monitor.

“DIGITAL THRU AES/EBU” Connector

This output carries an unaltered copy of the digital audio signal and can be used for daisy-chaining the signal up to three additional SAM monitors or subwoofers.

“ANALOG IN” Connector

The maximum input level of the analog input is +25.0 dBu. The analog input must not be overloaded, otherwise distortion will result. When the maximum input is exceeded, the enclosure front panel light turns red, indicating the overload.

The sensitivity of the monitor system is set using the GLM software. Coming from the factory, the analog input is set to the highest sensitivity, resulting in a sound output of 100 dB SPL for a -6 dBu analog input signal.

“CONTROL NETWORK” Connectors

The RJ-45 sockets connect the monitor to the proprietary Genelec Loudspeaker Manager™ (GLM™) network. Do not connect to Ethernet LAN.

“Loudspeaker Connectors” Group

These connectors are used when the RAM-L amplifier is mounted separately in an equipment rack.

1. “LED” Connector
This RJ-45 socket is a connection for the front panel warning LED.
2. “Woofers” Connector
A standard four-pole Speakon cable connects to the woofers.
3. “Midrange/Tweeter” Connector

A standard four-pole Speakon cable connects to the the midrange and tweeter.

Front Panel Light Functions

Green light on the DCW panel of a 1237A or 1238A enclosure indicates normal operation. A yellow light indicates certain activities when the GLM control software is used. The light turns red in an overload condition. The overload light (red) is activated by several events:

1. Exceeding the maximum input of the analog input
2. Reaching close to the digital input maximum (high likelihood of digital clipping)
3. Overload of drivers or amplifier, or clipping in the power amplifier
4. An error detected in the AES/EBU audio data

If a red warning light appears on the monitor enclosure, turn the source level down. Ensure that there are no bit errors in the AES/EBU digital audio data transmission.

Mounting RAM-L Amplifier in a 19 Inch Rack

The RAM-L amplifier can be removed from the enclosure and installed in a standard 19 inch rack. The rack mount components (front plate, brackets, screws) are included with the monitor.

Preparation for rack mount is done with the following process:

1. Remove all signal cables and the mains cable from the amplifier.
2. Remove the two screws attaching the amplifier to the vibration isolating mounts at the left top and bottom.
3. Pull out the left side of the amplifier (see figure 6).
4. Detach the flat cable from the enclosure.
5. Undo the two screws on the right side isolating mounts. Remove the amplifier.
6. Remove the cover of the flat cable connector (see figure 7)
7. Pull out (detach) the flat cable from the amplifier unit.
8. Reattach the cover of the flat cable connector.
9. Remove the front mounting ears (see figure 8).
10. Attach two angled rack mount back-

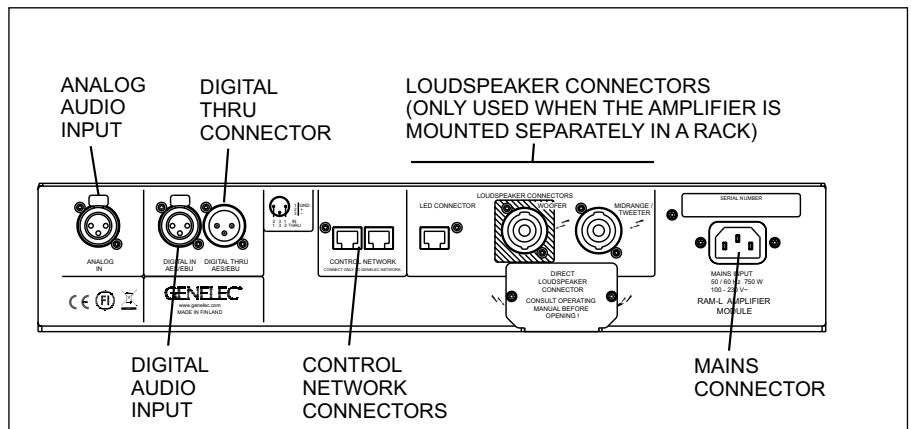

Figure 4. Connector panel of the RAM-L amplifier.

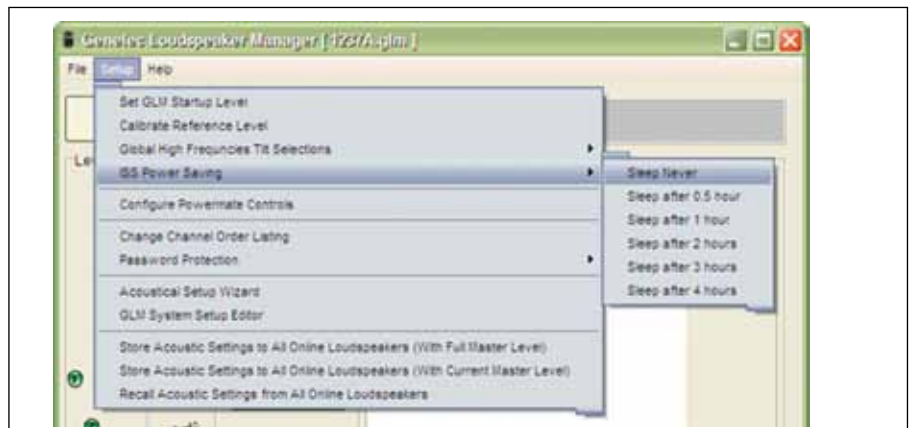

Figure 5. Selecting ISS setting.

ets (included). Attach the front plate (included) (see figures 9 and 10).

11. Attach the amplifier to a 19 inch rack.
12. Remove the plastic cover from the RJ45 connector. Attach two Speakon cables, and one RJ45 cable (LED CONNECTOR) between the amplifier and the cabinet.
13. Attach signal cables and the mains cable.

Flush Mounting the Monitor Enclosure

Flush mounting offers acoustical benefits. No cabinet edge diffraction will occur. Low frequency reflections from the wall behind the monitor can be avoided. The monitor's acoustical axis (Figure 1) should point to the seated listening position. The wall in which the monitors are mounted should be stiff and heavy. The monitors should not be mounted too high (maximum tilt angle < 15 degrees).

A space 50 to 100 mm (2 to 4") wide can be left around the monitor but this space should be covered with a panel in the front. Leave a gap of 5 to 10 mm (1/4 to 1/2") between

Cable gauge	Max. length
2,0 mm ² (14 AWG)	30 m (100 ft)
3,3 mm ² (12 AWG)	40 m (130 ft)
5,3 mm ² (10 AWG)	60 m (200 ft)

Table 1. Recommended cable thicknesses for different lengths of signal cable

the monitor and the panel. Fill this gap with a soft rubber gasket (see figure 14). The monitor should be mounted on vibration isolators. The resonant frequency of movement for the mounted monitor should be between 2 to 8 Hz.

An empty cavity in the wall should be filled with absorbent mineral wool or foam plastic. A wooden wall structure must be heavily braced (see figure 11). In a solid (e.g. concrete) wall structure, the space around the cabinet should be filled with absorbent mineral wool or sand bags (see Figure 12).

Ensure that the cabinet is flush with the surface of the wall. If a decorative cloth frame is used the edges adjacent to the monitors must be less than 20 mm (3/4 in) deep.

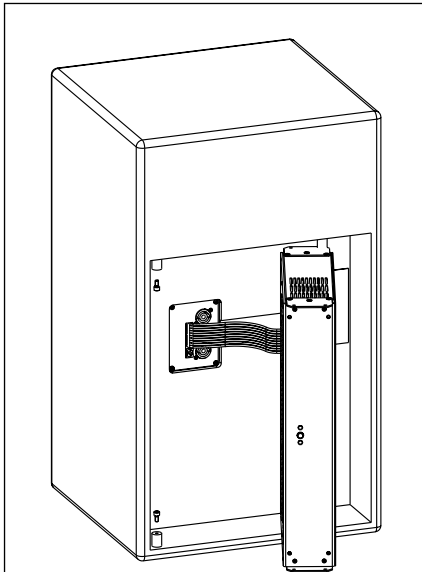

Figure 6. Pull out the left side of the amplifier and detach the flat cable from the enclosure.

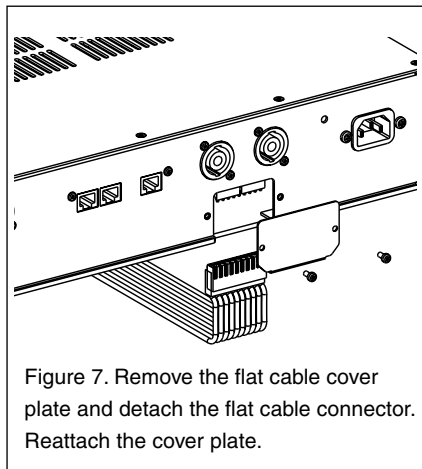

Figure 7. Remove the flat cable cover plate and detach the flat cable connector. Reattach the cover plate.

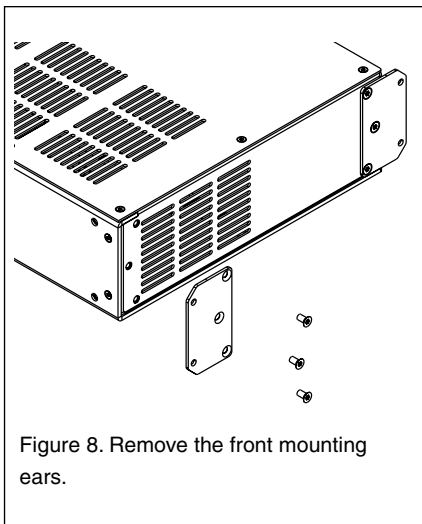

Figure 8. Remove the front mounting ears.

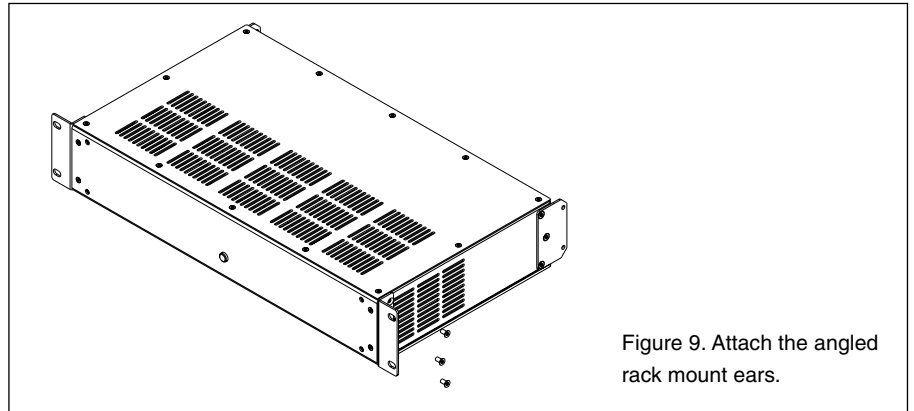

Figure 9. Attach the angled rack mount ears.

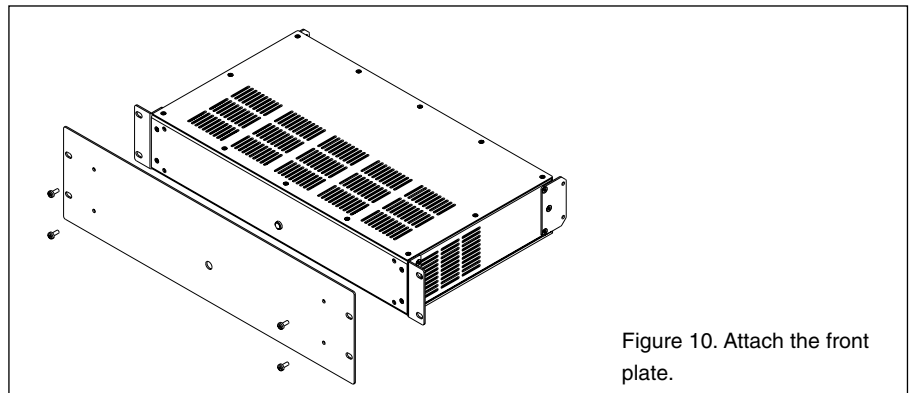

Figure 10. Attach the front plate.

The cloth must be acoustically transparent. Genelec-approved cloth grilles are available.

Testing Mode

Once on, when the power button is pressed for a long time, the RAM-L enters a mode for system testing. This special mode is intended for system debugging and testing. When the RAM-L is turned off, the special mode is reset. Upon restarting the RAM-L the current standard settings stored by GLM software are restored.

Test mode selection blinks the power button light (see Table 2). A special mode is activated by a long press on the power button. In a special mode the power button light remains on but blinks off 1-4 times indicating the mode currently selected.

The testing modes are not intended for continued operation. Use GLM software to set up permanent settings for 1237A and 1238A.

Safety Considerations

The 1237A and 1238A have been designed in accordance with international safety standards. To ensure continued safe operation and to maintain the monitor under safe operating conditions, the following warnings and precautions must be observed:

1. Servicing and adjustment must only be performed by qualified service personnel. The monitor enclosure or the amplifier enclosure must not be opened.
2. Do not use this product with a mains cable with no protective earth conductor, or a mains connection without the protective earth contact, as this may lead to personal injury.
3. To prevent fire or electric shock, do not expose the unit to water or moisture.
4. Do not place any objects filled with liquid, such as vases or water pipes on the monitor or near it.
5. Note that the amplifier is not completely disconnected from the AC mains service unless the mains power cord is removed from the amplifier or the mains outlet.
6. Free flow of air behind the monitor is necessary to maintain sufficient cooling. Do not obstruct airflow around the monitors.

WARNING!

The Genelec 1237A and 1238A monitors are capable of producing sound pressure levels in excess of 85 dB, which may cause permanent hearing damage.

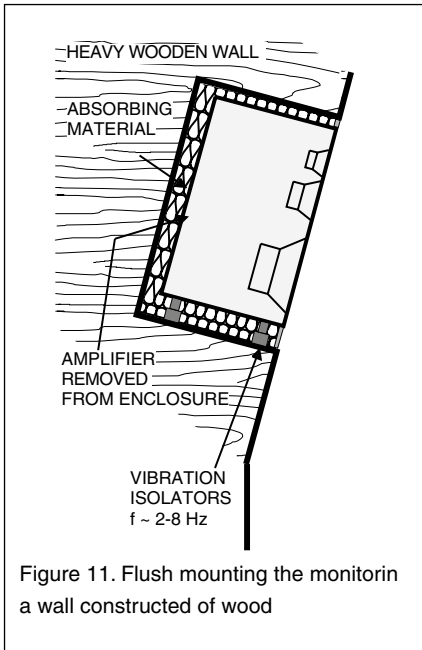

Figure 11. Flush mounting the monitor in a wall constructed of wood

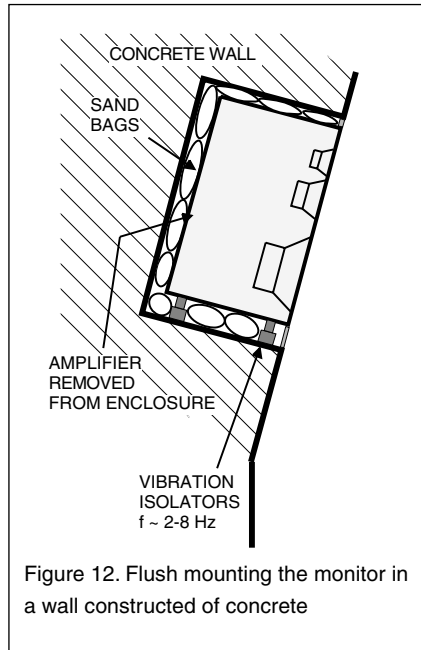

Figure 12. Flush mounting the monitor in a wall constructed of concrete

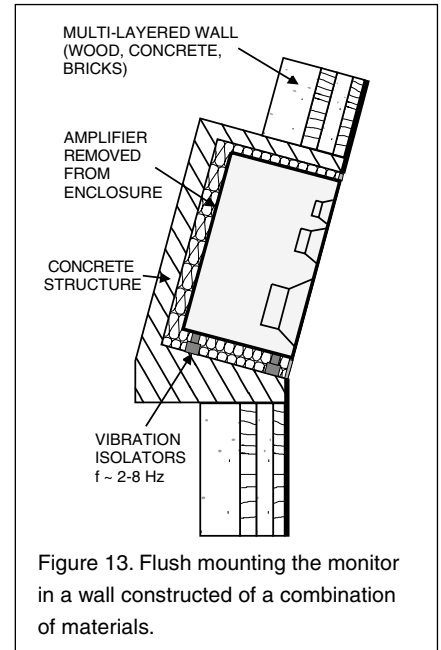

Figure 13. Flush mounting the monitor in a wall constructed of a combination of materials.

Button press	Function	Notes
Short press	Power on, power off	
Long press	Enter special mode, exit special mode	Press longer than 5 seconds
Special mode: one short press	Mode 1: AES/EBU channel A selected, room-related calibration in use	Power button light blinks once every few seconds
Short press advances	Mode 2: AES/EBU channel B selected, room-related calibration in use	Power button light blinks twice every few seconds
Short press advances	Mode 3: AES/EBU channel A selected, factory calibration in use	Power button light blinks three times every few seconds
Short press advances	Mode 4: AES/EBU channel B selected, factory calibration in use	Power button blinks four times every few seconds
Special selection: long press	Once a special mode 1-4 has been selected, a long press selects the special mode	Press longer than 5 seconds; the RAM-L selects the special mode and starts playing. To exit the special mode turn off the amplifier.
Special mode: no press for 60 seconds	RAM-L exits the special mode and turns off	Automatically happens if user does not press the power button

Table 2. Power button actions to activate testing modes

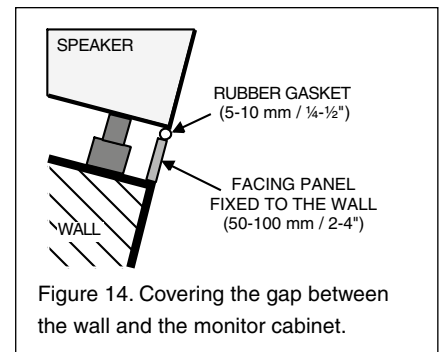

Figure 14. Covering the gap between the wall and the monitor cabinet.

Accessories

A wide selection of accessories is available for Genelec monitors. Consult the Accessories Catalogue on www.genelec.com or your local distributor/dealer for up-to-date information.

Compliance to FCC Rules

This device complies with part 15 of the FCC Rules. Operation is subject to the following two conditions:

1. This device may not cause harmful interference
2. This device must accept any interference received, including interference that may cause undesired operation.

Note: This equipment has been tested and found to comply with the limits for a Class B digital device, pursuant to part 15 of the FCC Rules. These limits are designed to pro-

Maintenance

No user serviceable parts are to be found within the monitor enclosure or the RAM-L amplifier unit. Any maintenance or repair of the monitor should only be undertaken by qualified service personnel.

Guarantee

Genelec 1237A and 1238A are supplied with a two year guarantee against manufacturing faults or defects that might alter the performance of the monitors. Refer to supplier for full sales and guarantee terms.

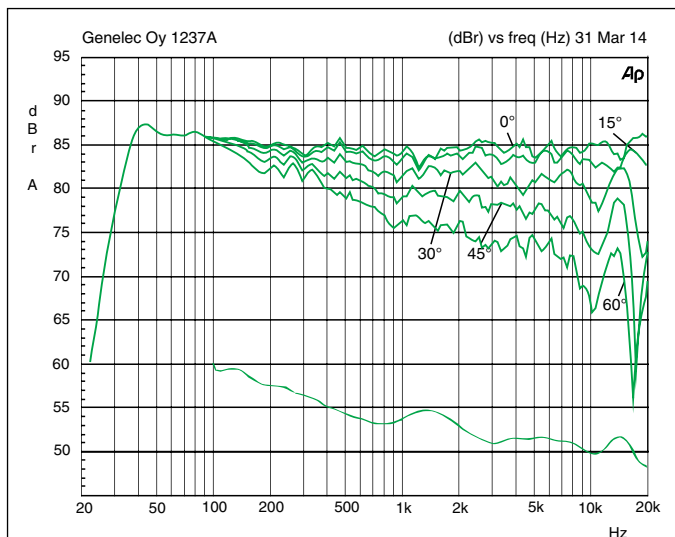

Figure 15. The upper curve group shows the horizontal directivity characteristics of the 1237A in its vertical configuration measured at 2 m. The lower curve is a 1/6 octave smoothed power response.

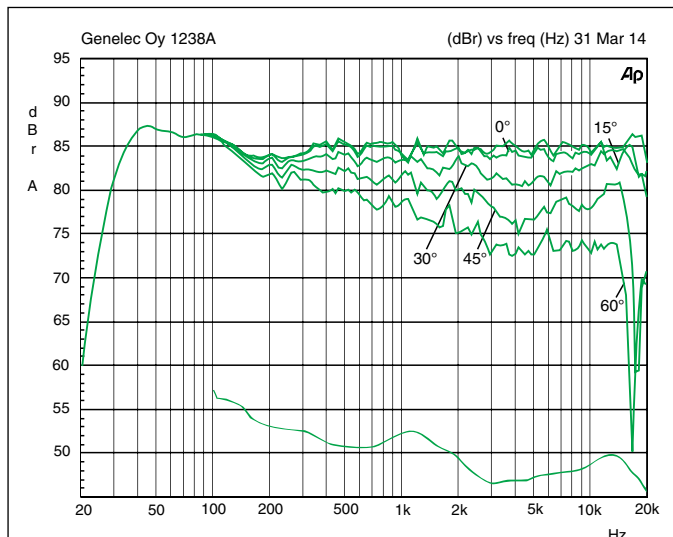

Figure 16. The upper curve group shows the horizontal directivity characteristics of the 1238A in its vertical configuration measured at 2 m. The lower curve is a 1/6 octave smoothed power response.

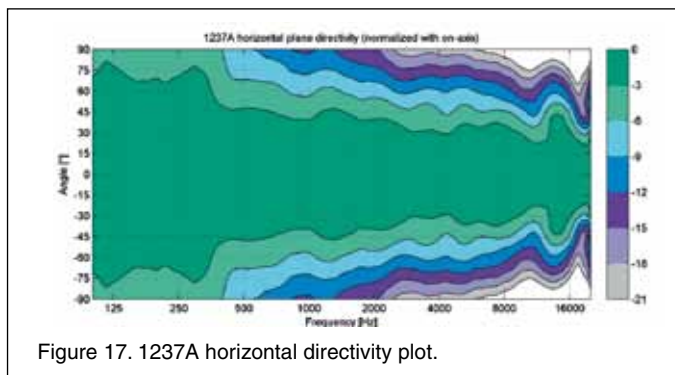

Figure 17. 1237A horizontal directivity plot.

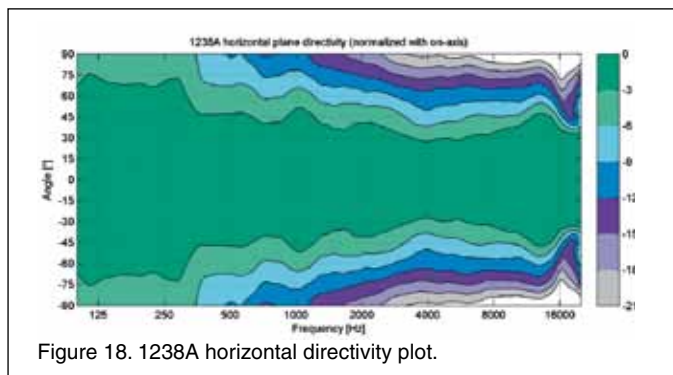

Figure 18. 1238A horizontal directivity plot.

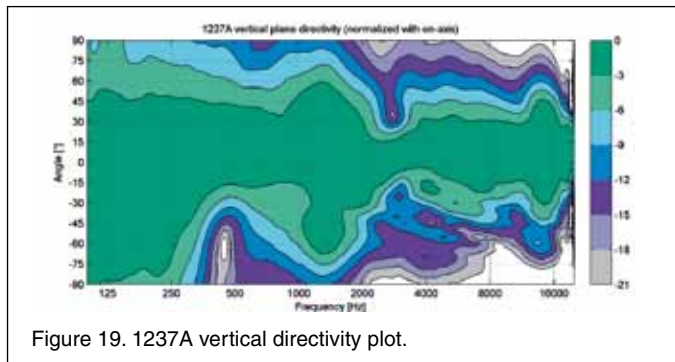

Figure 19. 1237A vertical directivity plot.

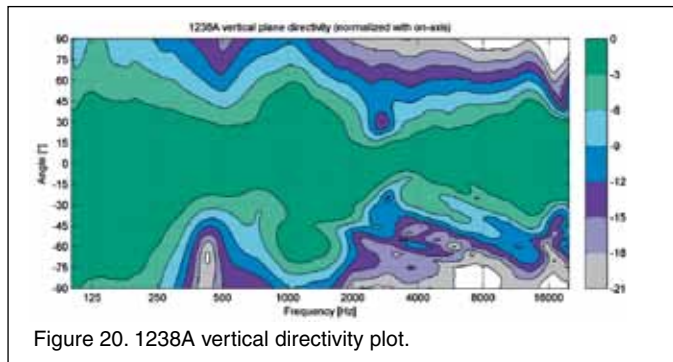

Figure 20. 1238A vertical directivity plot.

vide reasonable protection against harmful interference in a residential installation. This equipment generates, uses and can radiate radio frequency energy and, if not installed and used in accordance with the instructions, may cause harmful interference to radio communications. However, there is no guarantee that interference will not occur in a particular installation. If this equipment does cause harmful interference to radio or televi-

sion reception, which can be determined by turning the equipment off and on, the user is encouraged to try to correct the interference by one or more of the following measures:

1. Reorient or relocate the receiving antenna.
2. Increase the separation between the equipment and receiver.
3. Connect the equipment into an outlet on

a circuit different from that to which the receiver is connected.

4. Consult the dealer or an experienced radio/TV technician for help.

Modifications not expressly approved by the manufacturer could void the user's authority to operate the equipment under FCC rules.

1237A and 1238A Operating Manual

SYSTEM SPECIFICATIONS		
	1237A	1238A
Lower cut-off frequency, -3 dB	< 35 Hz	< 33 Hz
Upper cut-off frequency, -3 dB	> 21 kHz	> 21 kHz
Free field frequency response, ± 2.5 dB	37 Hz – 20 kHz	35 Hz – 20 kHz
Maximum short term sine wave acoustic output on axis in half space, averaged from 100 Hz to 3 kHz @ 1 m	> 118 dB SPL	> 121 dB SPL
Maximum long term RMS acoustic output in the same conditions with IEC weighted noise (limited by driver protection circuit) @ 1 m	> 112 dB SPL	> 116 dB SPL
Maximum peak acoustic output per pair in a listening room with music material @ 2 m	> 122 dB	> 124 dB
Self generated noise level in free space at 1 m on axis (A-weighted)	< 10 dB	< 10 dB
Harmonic distortion at 95 dB SPL at 1 m on axis Freq: 50...200 Hz > 200 Hz	< 3 % < 0.5 %	< 1 % < 0.5 %
Drivers Bass Midrange Treble	305 mm (12 in) cone 125 mm (5 in) cone 25 mm (1 in) metal dome	385 mm (15 in) cone 125 mm (5 in) cone 25 mm (1 in) metal dome
All drivers are magnetically shielded		
Weight (monitor with integrated amplifier)	42 kg (93 lb)	57 kg (126 lb)
Weight (monitor with amplifier removed)	36 kg (80 lb)	51 kg (113 lb)
Amplifier weight	6 kg (13 lb)	
Dimensions (monitor enclosure) Height Width Depth	680 mm (26 ³ / ₄ in) 400 mm (15 ³ / ₄ in) 380 mm (15 in)	810 mm (32 in) 480 mm (19 in) 420 mm (16 ¹ / ₂ in)
Amplifier dimensions (in rack mount configuration) Height (front panel) Height (amplifier casing) Width (front panel) Width (amplifier casing) Depth	3U 132 mm (5 ¹ / ₈ in) 80 mm (3 ¹ / ₈ in) 483 mm (19 in) 425 mm (16 ³ / ₄ in) 252 mm (9 ¹⁵ / ₁₆ in)	

AMPLIFIER SECTION		
	1237A	1238A
Bass amplifier short term output power	500 W	
Midrange amplifier short term output power	250 W	
Treble amplifier short term output power	200 W	
Long term output power is limited by driver protection circuitry		
Amplifier system THD at nominal output	< 0.01 %	
Signal to Noise ratio, referred to full output		
Bass	>115 dB	
Midrange	>115 dB	
Treble	>115 dB	
Mains voltage	100-240 VAC, 50/60 Hz	
Power consumption		
Standby	<0.5 W	
Idle	25 W	
Full output	750 W	

SIGNAL PROCESSING SECTION		
	1237A	1238A
Analog signal input connector XLR female, balanced 10 kOhm	pin 1 gnd pin 2 non-inverting, pin 3 inverting	
Maximum analog input signal	+25.0 dBu	
Analog input sensitivity (100 dB SPL at 1 m)	-6 dBu	
Analog input gain selection	0, +6, +12, +18 dB	
Digital signal input connector XLR female 110 Ohm	AES/EBU Single Wire or Dual Wire	
Digital signal output / Thru connector XLR male 110 Ohm	AES/EBU Single Wire or Dual Wire	
Digital audio input Word length	16 - 24 bits	
Sample rate	32 - 192 kHz	
Digital input sensitivity (100 dB SPL at 1 m)	-30 dBFS	
Digital input gain selection	0, +6, +12, +18 dB	
Control network Type Connection	Proprietary GLM™ network 2 RJ45, CAT5 cables	
Crossover frequency Bass/Mid Mid/Treble	450 Hz 3.0 kHz	420 Hz 3.0 kHz
GLM™ software frequency response adjustment Notch filters Shelving filters	4 LF and 2 HF 2 LF and 2 HF	
System calibration	Genelec GLM AutoCal™	