



MARTEN

EXPERIENCE THE NEXT LEVEL

# COLTRANE 3



---

MADE IN SWEDEN



## COLTRANE 3

The new Coltrane 3 is a landmark creation, a technical tour de force that brings together Marten's most advanced research and sound engineering to date. It features the same groundbreaking technology first developed for the Coltrane Supreme 2, all beautifully packaged in a more lounge-friendly form.



From the cabinets to the smallest components, the Coltrane 3 uses exclusive, premium materials to continue the Coltrane commitment to superior structure and sound.

First order filters and CELL concept drivers developed in partnership with Accuton deliver a sound that is perfectly time and phase coherent. The tweeters, midrange and bass drivers have identical acoustic centres to give outstanding timing and flow. And distortion is unbelievably low, for superb levels of detail and resolution, with minimal colouring of the sound, even at high volume.

## THE EVOLUTION OF COLTRANE

---

The Coltrane series began when lead designer, Leif Mårten Olofsson developed his first 3-way speaker. They were some of the first speaker models to employ a pure diamond tweeter combined with a carbon fibre cabinet, a combination that produced outstanding results.

*2003*

The first Coltrane model took Marten outside Scandinavia to reach a greater international audience

*2006*

The Coltrane Supreme established Marten as a leading name in high-end hi-fi

*2014*

The Coltrane Supreme 2 employed the new CELL drivers and a first order crossover to create unique time and phase coherence

*2015*

The Coltrane 3 takes the audio experience to the next level, combining the best Marten technology and design to date

# COLTRANE 3

These 3 way speakers employ the newly developed Cell drivers. The Cell tweeter cone is made of pure diamond. The Cell mid range unit is made from a new pure ceramic, premiered in Coltrane 3. 1st order crossover – a feature first developed for the Coltrane Supreme 2. Based on the joint venture with Accuton and their CELL technology, it creates a sound that is 100% time and phase coherent. Front – extremely rigid featuring a new aluminium layer sandwiched between two wooden layers.

- Stand – bigger and sturdier than Coltrane 2
- Wheel mounts – for easy handling and fine-tuning
- Superior Bass control – a greater selection of levels to choose from
- Finishes – available in a new wider selection of colourways and finishes

## CELL concept drivers

Our joint venture with Accuton represents a new milestone in hi-fi history. Accuton developed the unique CELL concept drivers used within the Coltrane 3. Tweeters, midrange and bass drivers have identical acoustic centres, delivering flawless phase and time coherency. The domes in the units are perfectly rigid, for impeccable signal settle and piston behaviour. And there is incredibly low distortion, in the magnitude of electronic devices, even at high levels.

- Steady decay of higher order harmonics
- High bandwidth

CELL  
concept drivers

accuton®  
cooperation



## Technical specifications

**Frequency range** / 20-60000 Hz +-2dB

**Power rating** / 350 W

**Sensitivity** / 88 dB / 1 m / 2.83V

**Impedance** / 6 ohm (3.7 Ohm min)

**Type** / 3-way bass reflex

**Drive units** / 2x10" aluminium sandwich, 1x7" ceramic, 1x1" diamond

**Crossover frequency** / First order: 320 & 3800 Hz

**Terminals** / WBT Nextgen bi-wiring

**Internal wiring** / Jorma Design

**Cabinet** / 25 mm:s carbon fibre laminate cabinet, 68 mm laminated wood/aluminium front

**Stands** / Brushed stainless steel with Black Diamond Racing pucks and cones

**Dimensions (WxHxD)** / 39.5 cm x122 cm x 64 cm (15.5" x 48.0" x 25.2")

**Net weight** / 95 Kg (209 lbs)

## Finishes

All models have high-gloss carbon fibre cabinets with fronts available in:



Metallic Warm Grey



Metallic Bronze



Metallic Dark Gold



Matt Walnut

Please note Colours may not be a true representation of actual finish.

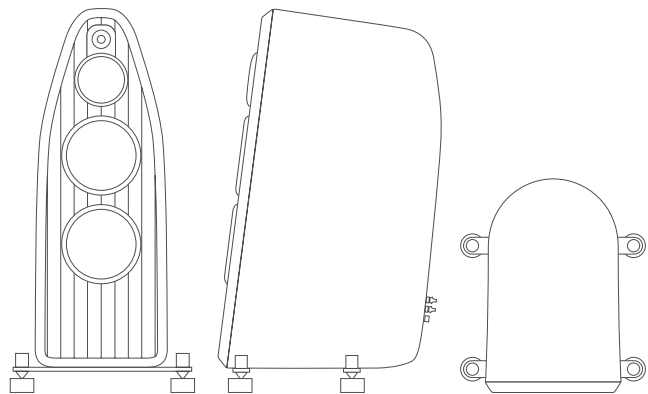

  
**MARTEN**

Marten  
Chalmersgatan 24  
SE-411 35 Gothenburg  
Sweden

Tel: +46 31 20 72 00  
Fax: +46 31 20 72 70  
info@marten.se  
www.marten.se

Made in Sweden