

**amphion**<sup>®</sup> enjoy

# Krypton3X

Reference manual  
5/2023



beautifully honest

## Contents

Introduction	4
Warranty and support	6
Krypton3X	
Story	8
Technologies	10
Features	12
Instructions	14
Technical specifications	16

## Introduction

---

### Welcome

Thank you for choosing Amphion Krypton3X. This is a project 25 years in the making. Plenty of audiophiles spend a lot of money on their systems without a thought nor a cent going into room acoustics. It is painstakingly common to find expensive systems, which are not even close to what they should be. The bigger the loudspeaker, the tougher the room matching becomes. We have tried to make Krypton as room friendly and system friendly as possible. This is done with a single, simple goal in mind: We would like you to forget your new speakers and focus on the large clean window they hopefully open to your music. Music is a very personal thing and the only way to push the envelope is to ask people to give their feedback. We would love to hear from you. Please share your feedback on what works and what could be done differently. Tell us about your favourite records. Show us the new good far away homes you have provided for our products.

Now unpack, connect, sit back, and experience it. Enjoy!



**Anssi Hyvönen**  
Founder & Managing Director, Amphion Loudspeakers Ltd.

---

### Company profile

**Amphion Loudspeakers Ltd.** was established in 1998.

We design and build loudspeakers that are characterised by a high-resolution, unstrained low-level reproduction and a pure driver integration. Our affordable solutions are rather insensitive to room acoustics and fill any space with a wide and even dispersion. A timeless yet flexible approach with regard to aesthetics and application make Amphion products easy to match with individual styles and preferences.

All products are handmade in Finland to ensure enduring listening quality.

---

### Follow us

[amphion.fi](http://amphion.fi)

#### Social media

-  [www.facebook.com/AmphionLoudspeakers](http://www.facebook.com/AmphionLoudspeakers)
-  [twitter.com/amphion\\_fi](https://twitter.com/amphion_fi)
-  [www.youtube.com/user/AmphionLoudspeakers](http://www.youtube.com/user/AmphionLoudspeakers)
-  [www.instagram.com/amphion\\_loudspeakers](http://www.instagram.com/amphion_loudspeakers)

## Warranty and support

### Warranty

Amphion Enjoy products come with a five-year warranty against defects in materials and our workmanship. For warranty or out-of-warranty service, in the first instance please contact your original dealer, and provide a copy of the original sales receipt. If you require additional assistance, please contact your local country distributor. If you have difficulty making contact with either of the above, please contact our headquarters. For proper unpacking, installation, positioning, and maintenance instructions, please first check this manual thoroughly.



Please do not return/ship any product to amphion nor its resellers without prior authorisation.

### Handmade in Finland

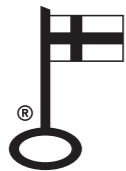

Amphion Loudspeakers Ltd. is awarded the right to use the Association for Finnish Work's Key Flag Symbol mark of origin. This mark is granted to Finland-based organizations that manufacture their products in Finland, having a minimum domestic content of 50 percent.

### Contact information

#### Amphion Loudspeakers Ltd.

Telkkistentie 2  
70460 Kuopio  
Finland

+358 17 2882100  
info@amphion.fi

## Krypton

### Story

Krypton3X is a highly innovative three-way, four-driver vented, floorstanding passive speaker which makes it possible to enjoy full range, realistic level, orchestral performances without owning a concert hall. You can feel the “presence” of performers and hear the individual definition of each instrument. Using waveguide technology and controlled dispersion technologies, Krypton3X helps you hear more of your music, and less of your room.



Amphion's Krypton3X is the flagship model of the its hifi (Amphion Enjoy) line.

A floorstanding unit, it is available in standard white, black or walnut veneer. For your reference, the Krypton3X's full technical specifications are listed at the rear of this manual.



Standard white (RAL 9010)

Black (RAL 9005)

Veneer

## Technologies

The Krypton's three-way design configuration is two midranges or mid/woofers (two proprietary paper/papyrus midrange drivers combining wood and cane) in a cardioid enclosure (for control of dispersion of the speaker) placed vertically above and below the (titanium) tweeter, and operating in parallel to implement a three-way crossover. This geometric arrangement of the drivers eliminates lobing error; is independent of inter-driver phase relationships; has no effect on crossover selection; eliminates off-axis nulls; and provides another polar response when the drivers are not driven in phase.

The Krypton's design incorporates a technology called U/D/D - Uniformly Directive Diffusion. U/D/D helps speakers keep their clarity and naturalness, even when placed close to boundaries - be there walls, bookshelves or desktops.

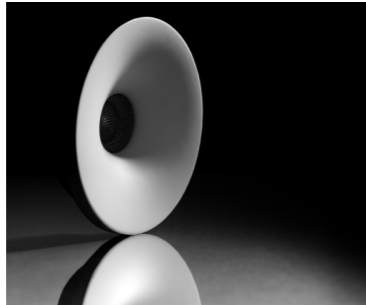

What is a Waveguide? A waveguide is a generic term to describe a structure that guides waves with minimal loss of energy by restricting their expansion to one or two dimensions. A loudspeaker's diaphragm coupled directly to ambient air is a poor impedance match. Amphion speakers are recognised for their use of tweeter waveguides in front of the driver to control the speaker's directionality.



## Features

①

The highly innovative cardioid midrange allows Kryptons to perform well even in small rooms, close to big windows, and under other acoustic irregularities which traditional speakers cannot cope with. Both midrange drivers work in their own chambers, side vented by holes drilled in the shape of an acute triangle.

②

Krypton's proprietary paper-papyrus 8" (203mm) midrange is actually many drivers in one and due to careful driver placement, and together with the tweeter, forms a perfect time-accurate point source which works from 160 Hz and upwards. Inside the critical 600-2000 Hz hearing-range, the cone's "ribs" transform the unit to work similarly to 4" (102mm), which leads to air and nuances, but will take full advantage of low distortion and high power handling of the 8" units.



③

The midrange clarity coupled with the power which can be achieved by the Krypton's two corrugated 8" units working in unison makes you wonder how you ever could live with the 6.5" (165mm) other manufacturers offer at this price point.

④

Krypton reduces unwanted sound reflections from both the side and back-walls (by up to 20 dB).

⑤

Krypton's 10" (254mm) woofer has an aluminum diaphragm, thick rubber front suspension, and a large double magnet. It is mounted on the side of the cabinet so that the speakers can be positioned with the woofers facing either inside (standard room placement) or outside (for a broader soundstage). The woofer is mounted into a vented enclosure with the vent itself located between the midrange drivers' chambers.



## Instructions

### Unpacking

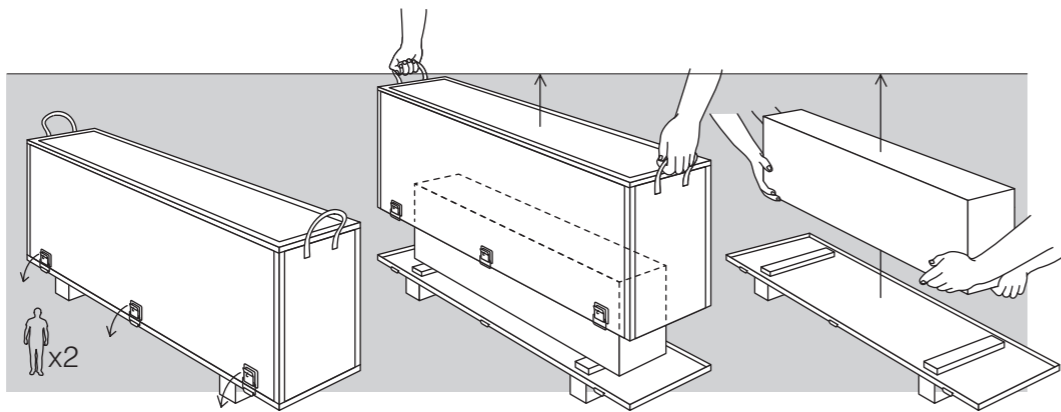

### Connecting

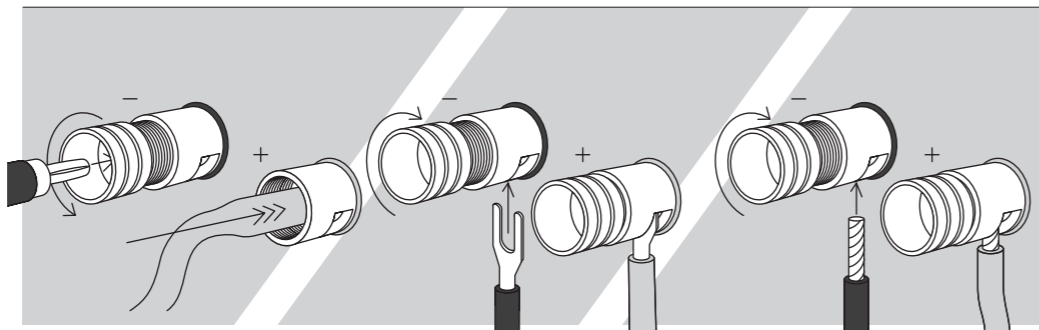

### Care

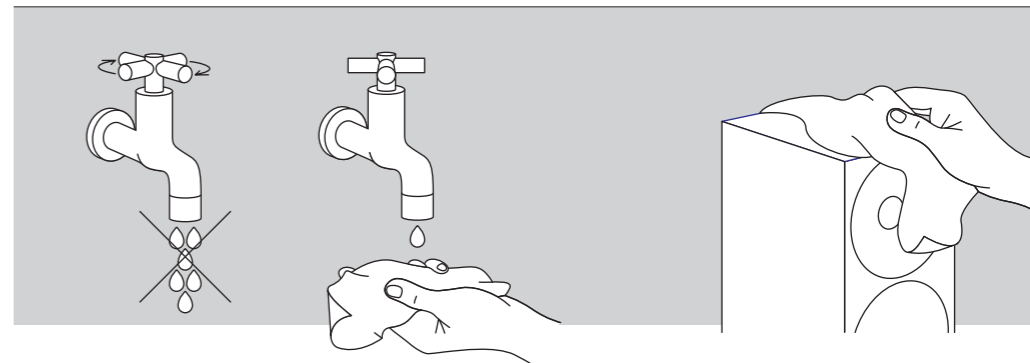

### Individual support

Typically, a wide variety of factors influence loudspeakers' performance. Please contact your local Amphon dealer or sales representative for specification, connectivity and positioning recommendations for your specific system. For more information, you can also be in touch with Amphon headquarters.



## Technical specifications

### Physics

Operating principle	Three-way, vented
Tweeter	1" titanium
Mid / woofer	2 x 8" paper / 10" aluminum
Measurements	1370 x 240 x 470 mm
Weight	70 kg (154 lbs)

### Performance

Crossover point	160 Hz / 1600 Hz
Impedance	4 $\Omega$
Sensitivity	89 dB
Frequency response	21 - 25 000 Hz +/-3dB
Power recommendation	100 - 300 W

### Variations

Monochrome	 
Wood veneer	



### Directivity plot

101-14050 Hz

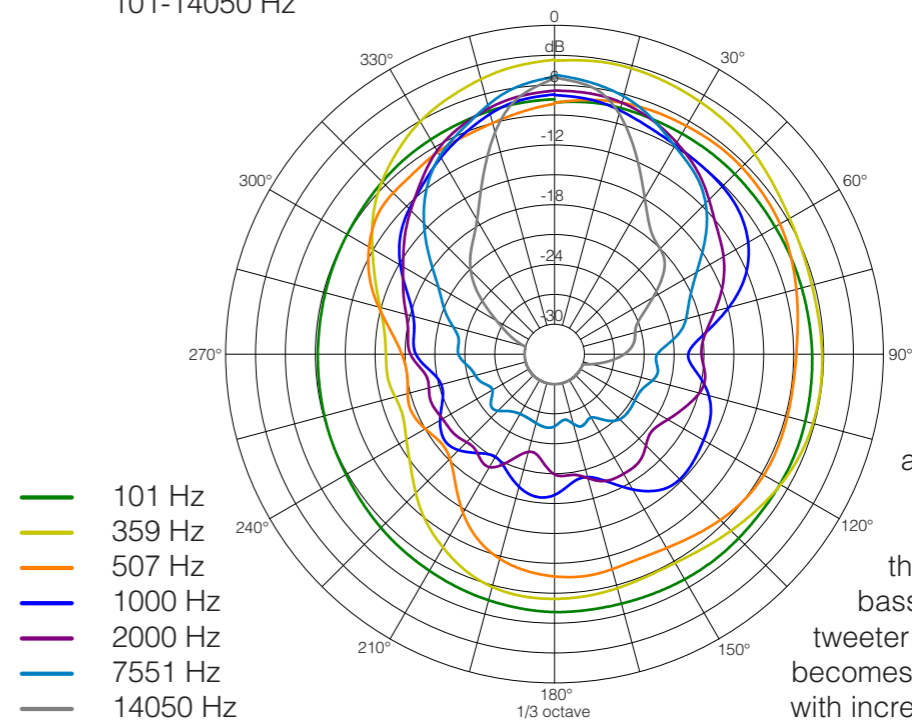

The controlled directivity of the midrange drivers helps to achieve a smooth and natural transition from the non-directional bass response to the tweeter response, which becomes more directional with increasing frequency.

amphion.fi



Amphion Loudspeakers Ltd.

Telkkistentie 2  
70460 Kuopio  
Finland

+358 17 2882100  
[info@amphion.fi](mailto:info@amphion.fi)  
[amphion.fi](http://amphion.fi)